

AUDL GS08/GAV1

Auditory Perception

Envelope and temporal fine
structure (TFS)

Envelope and TFS arise from a
method of decomposing
waveforms

The 'classic' decomposition of waveforms

- Spectral analysis ...
 - Decomposes a complex wave into a sum of sinusoids to give a *spectrum*

Adding waves (time domain)

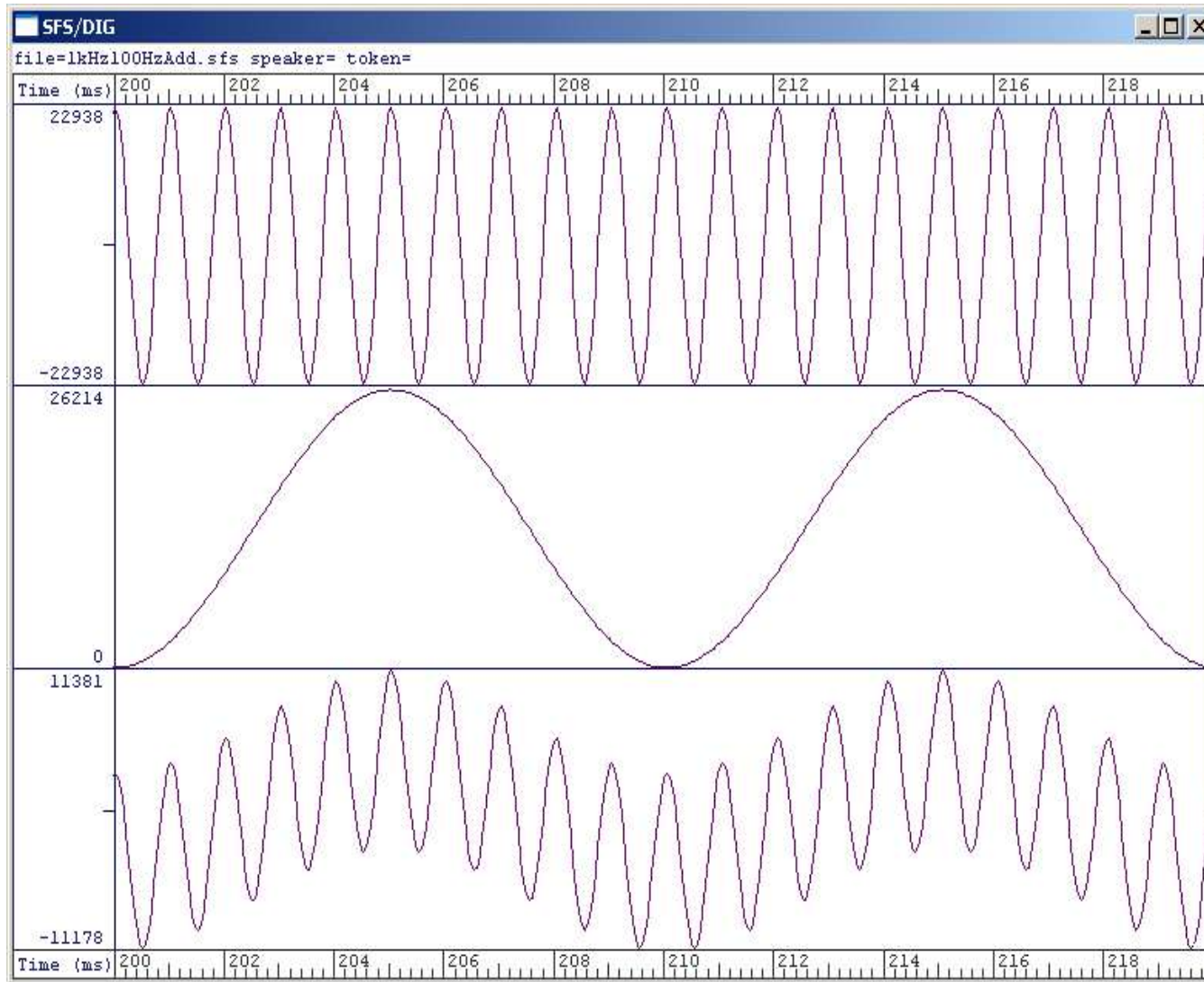

1 kHz sinusoid



+

100 Hz sinusoid



=

a complex wave
(with two spectral
components)



Adding waves (frequency domain)

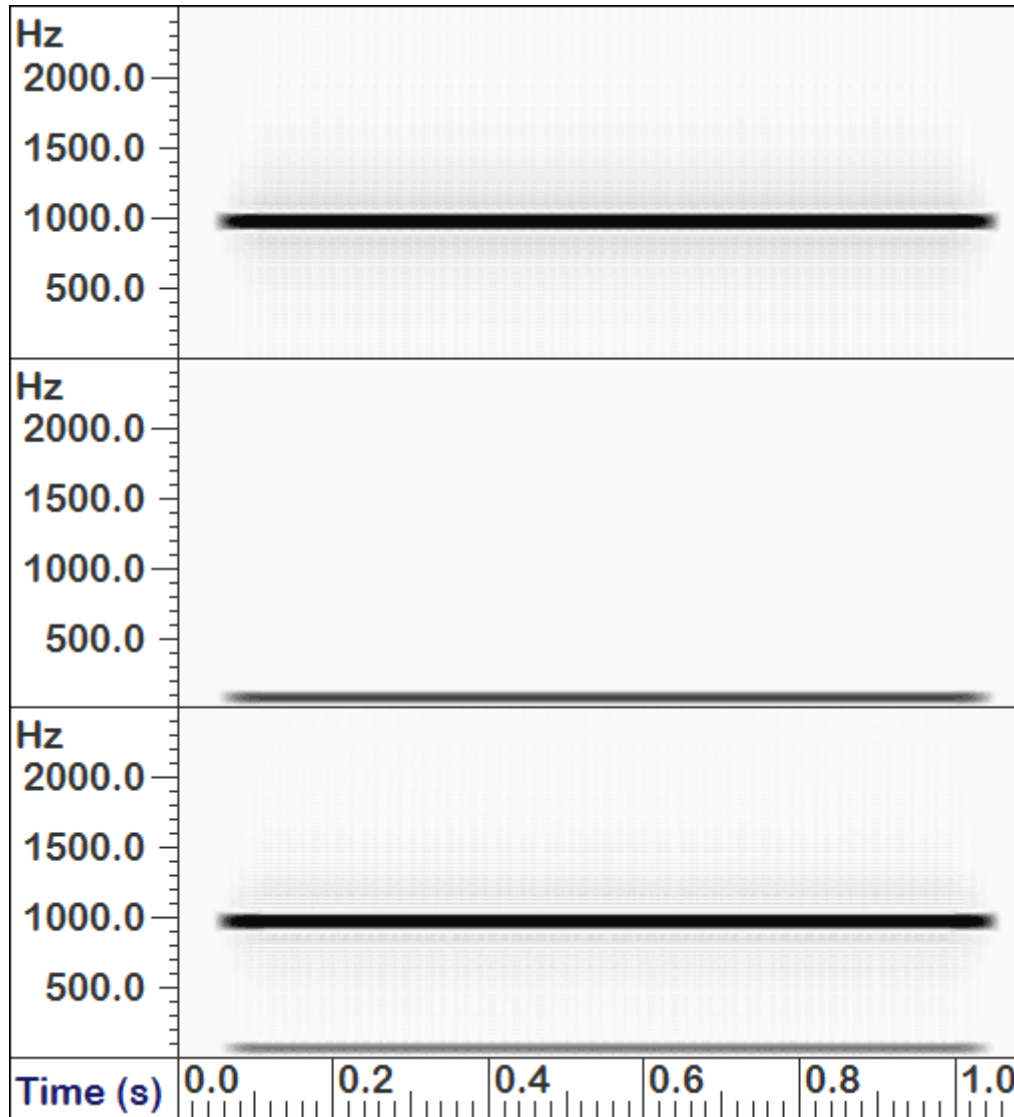

1 kHz sinusoid

+



100 Hz sinusoid

=



a complex wave
(with two spectral
components)

A less familiar way of
decomposing waveforms in the
time domain ...

based on *multiplication*.

Multiplying (*modulating*) waves

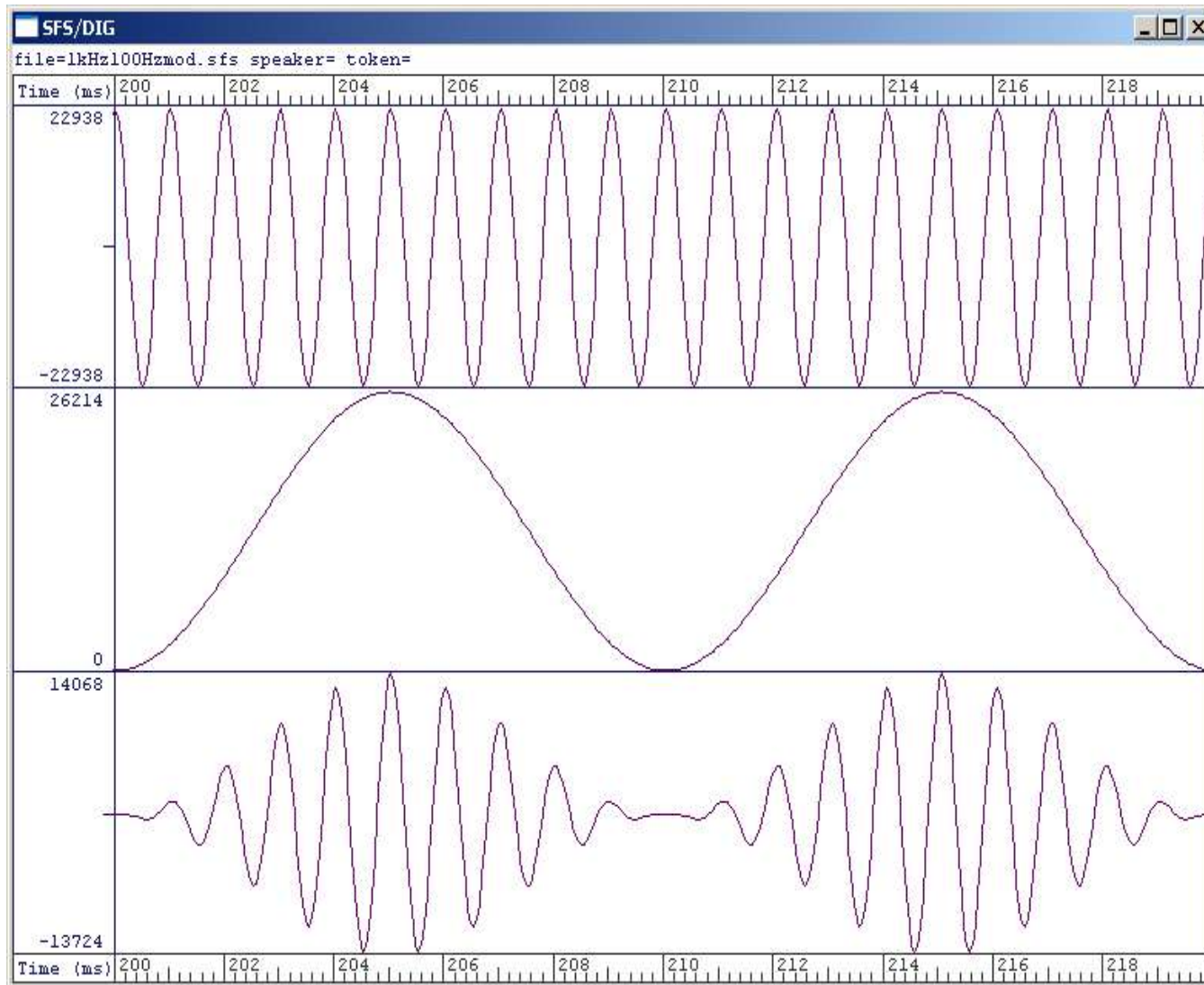

carrier at 1 kHz
(fine structure)



x

modulator at 100
Hz
(envelope)



=

amplitude-
modulated wave

Multiplying (*modulating*) waves

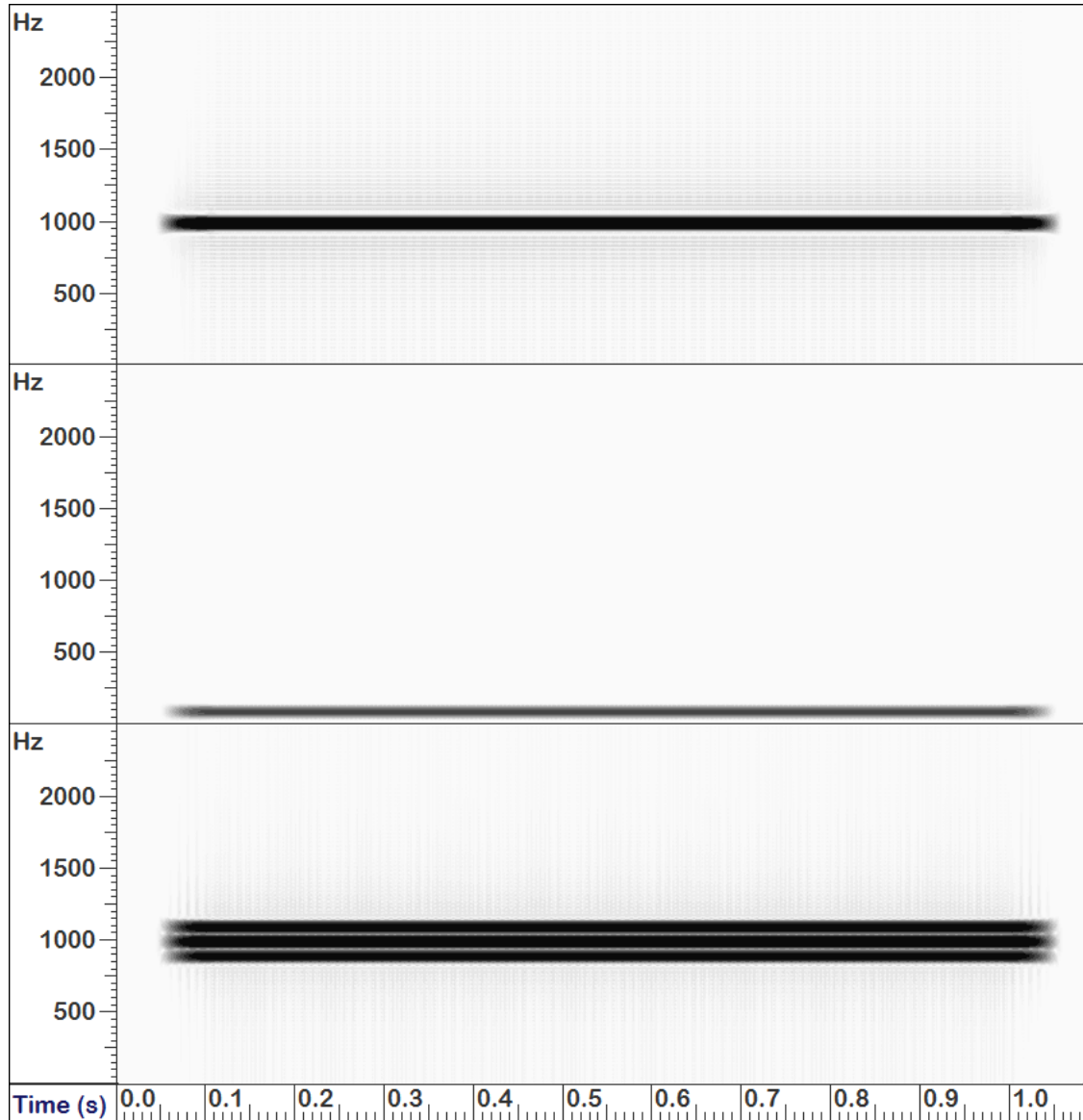

carrier at 1 kHz
(fine structure)



x

modulator at 100
Hz
(envelope)



=

amplitude-
modulated wave

Can work this backwards too

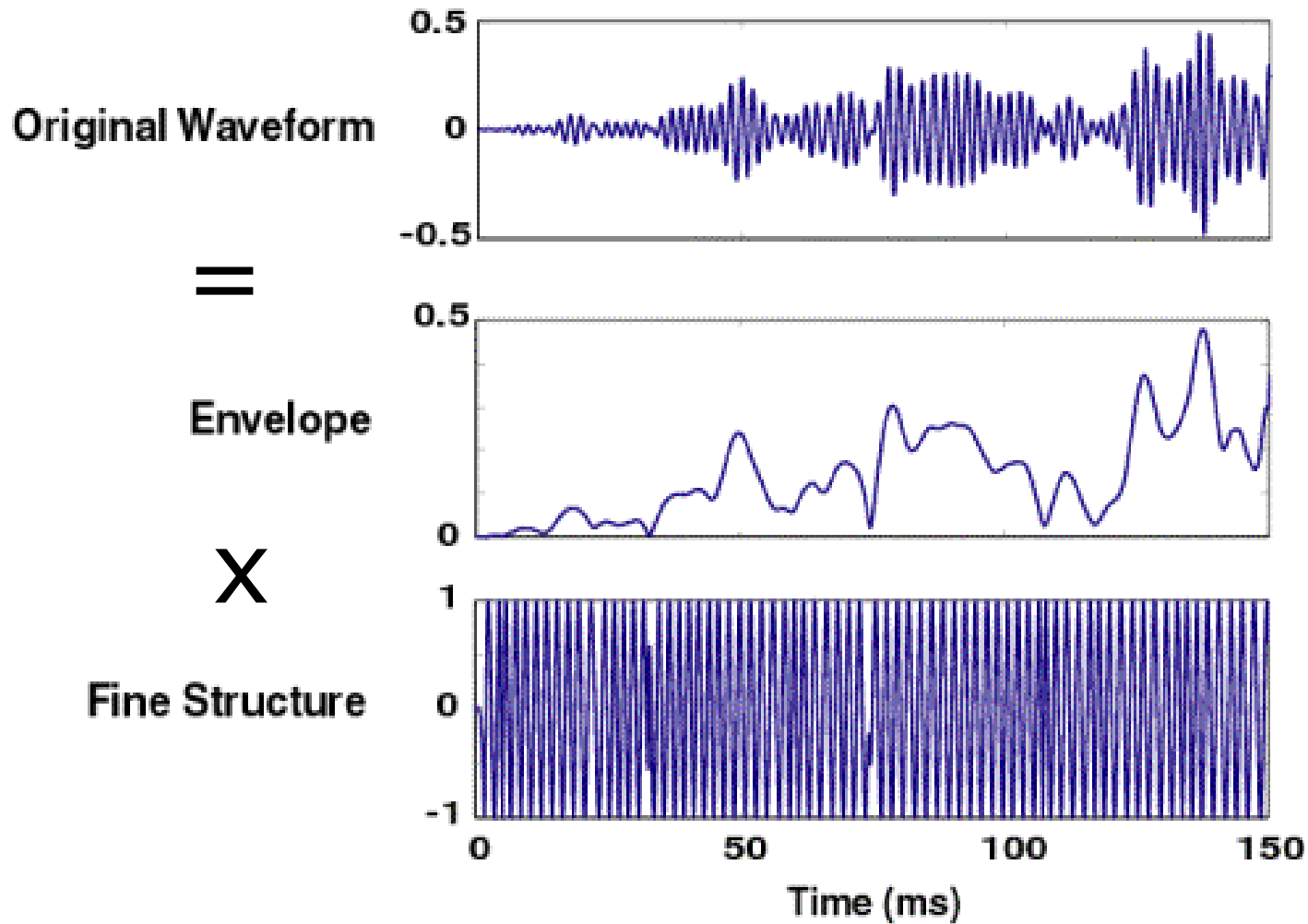

Extracting envelopes

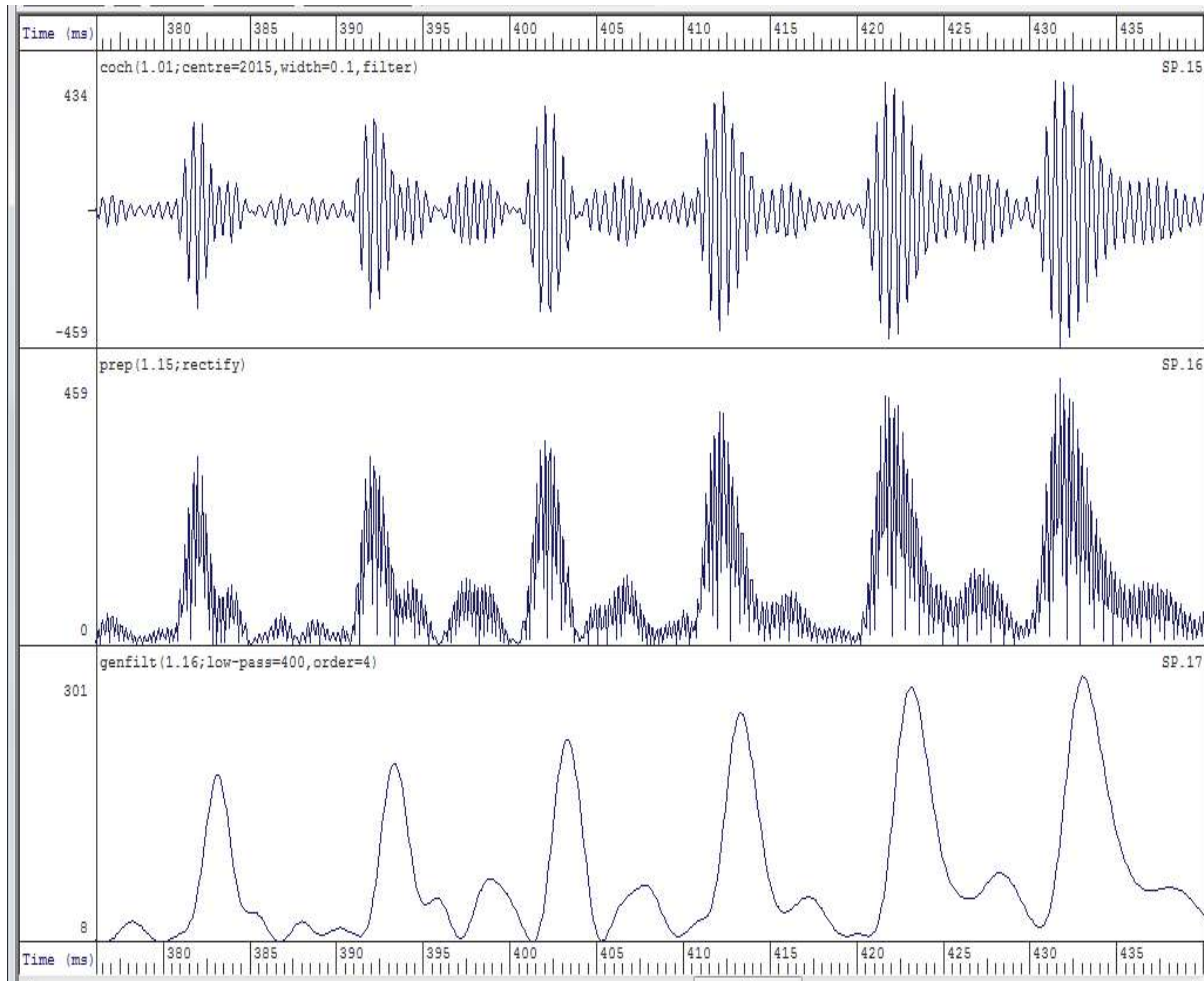

original wave

full-wave rectification

smoothing at 400 Hz
(low-pass filtering)

A Hilbert transform

- can uniquely decompose a wave into the *product* of two waves
 - *envelope*
 - *temporal fine structure* (TFS)
- Unlike spectral analysis, the constituent waves are usually complicated
- A warning!

The outcome of a Hilbert decomposition

$$x(t) = ENV(t) \cdot \sin[2\pi ft + \Theta(t)]$$

a time-varying
envelope

a constant amplitude
sinusoid varying in
frequency/phase

think of all waves as being made by multiplying one wave (the *envelope*) against another (the *temporal fine structure*)

There's more than one way to extract an envelope

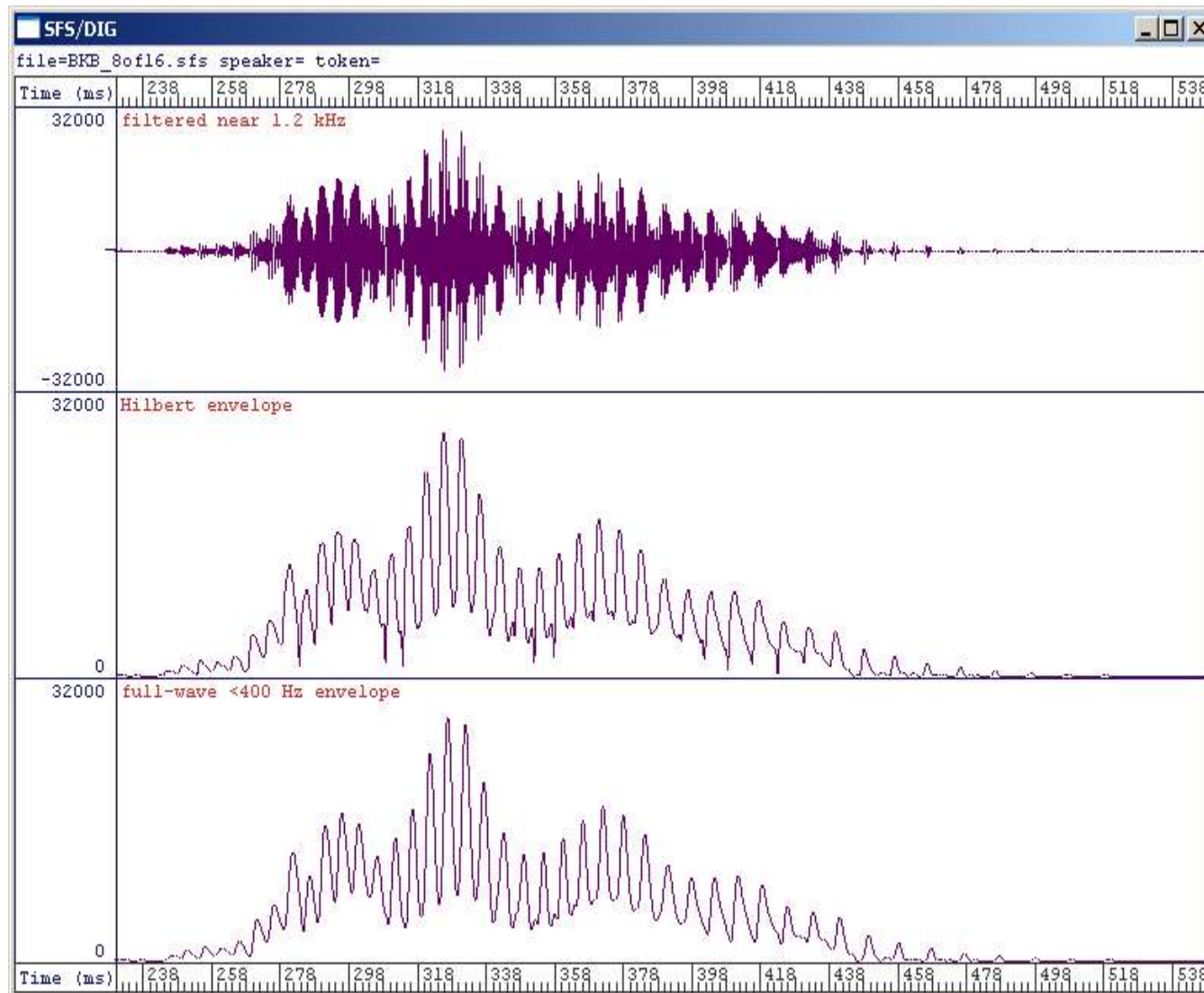

original wave

Hilbert envelope

envelope from full-wave rectification and smoothing at 400 Hz

A simple example: a tone pulse

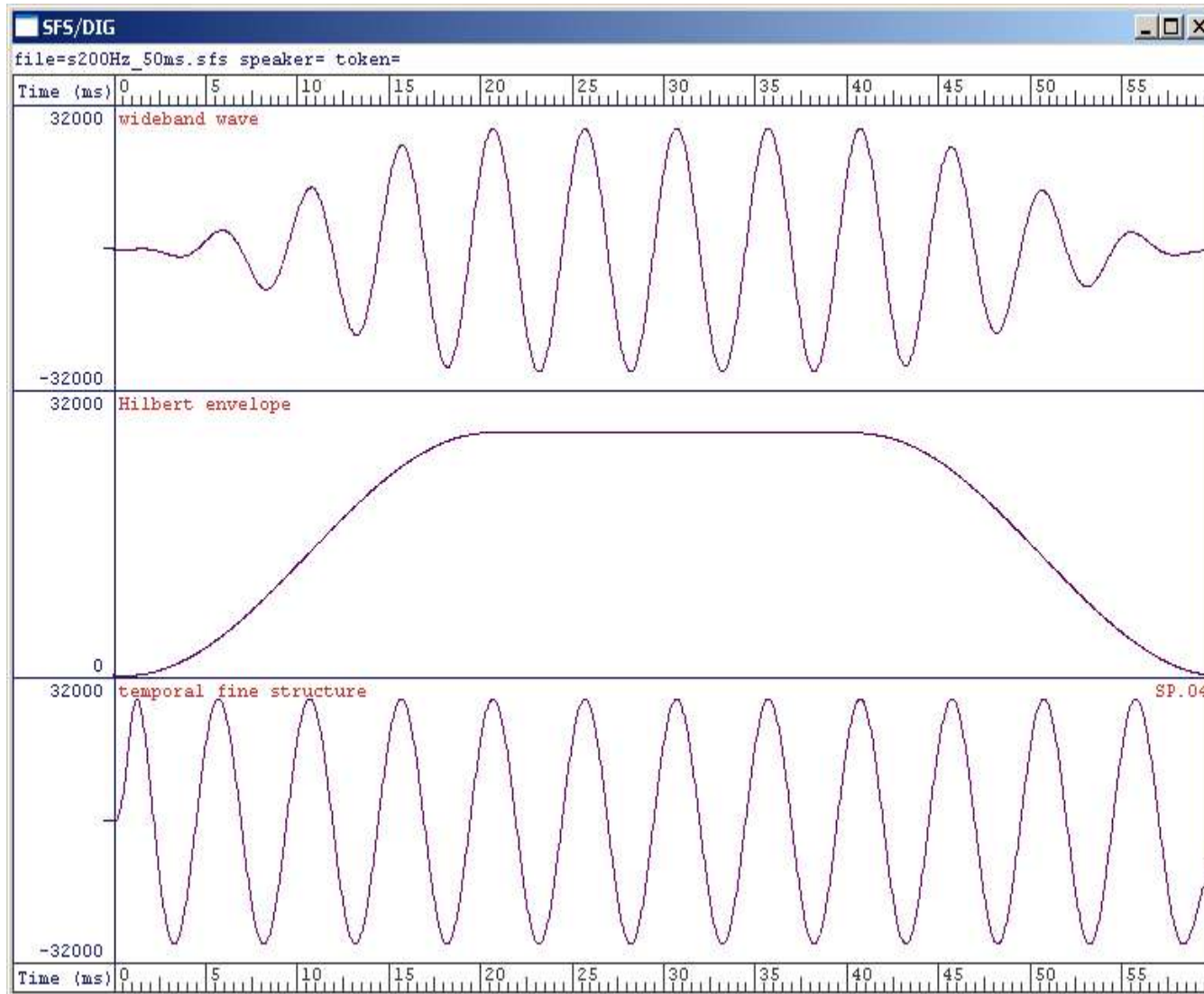

original wave

=

envelope

x

TFS

A simple example: a noise pulse

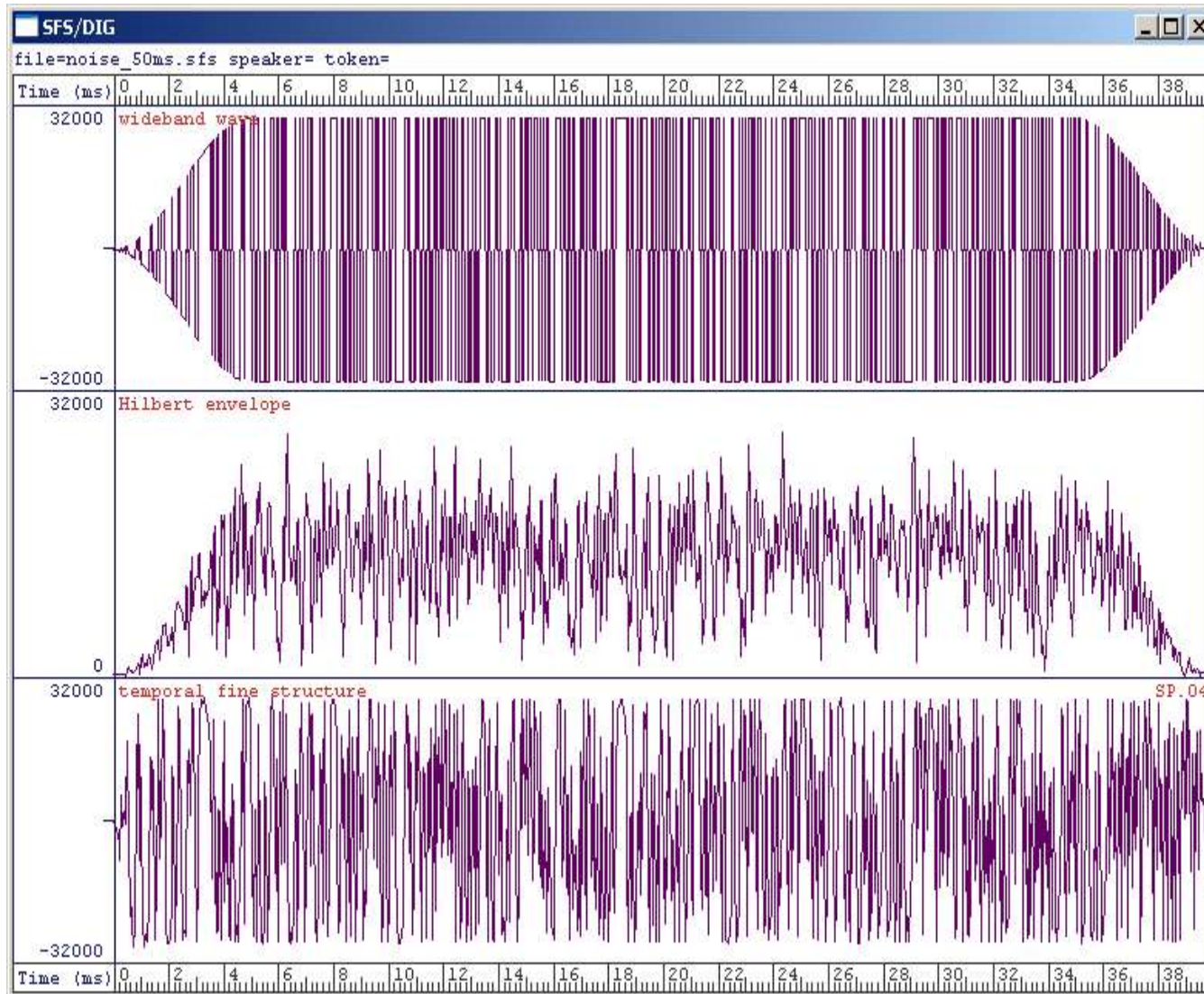

original wave

=

envelope

x

TFS

A simple example: a sawtooth

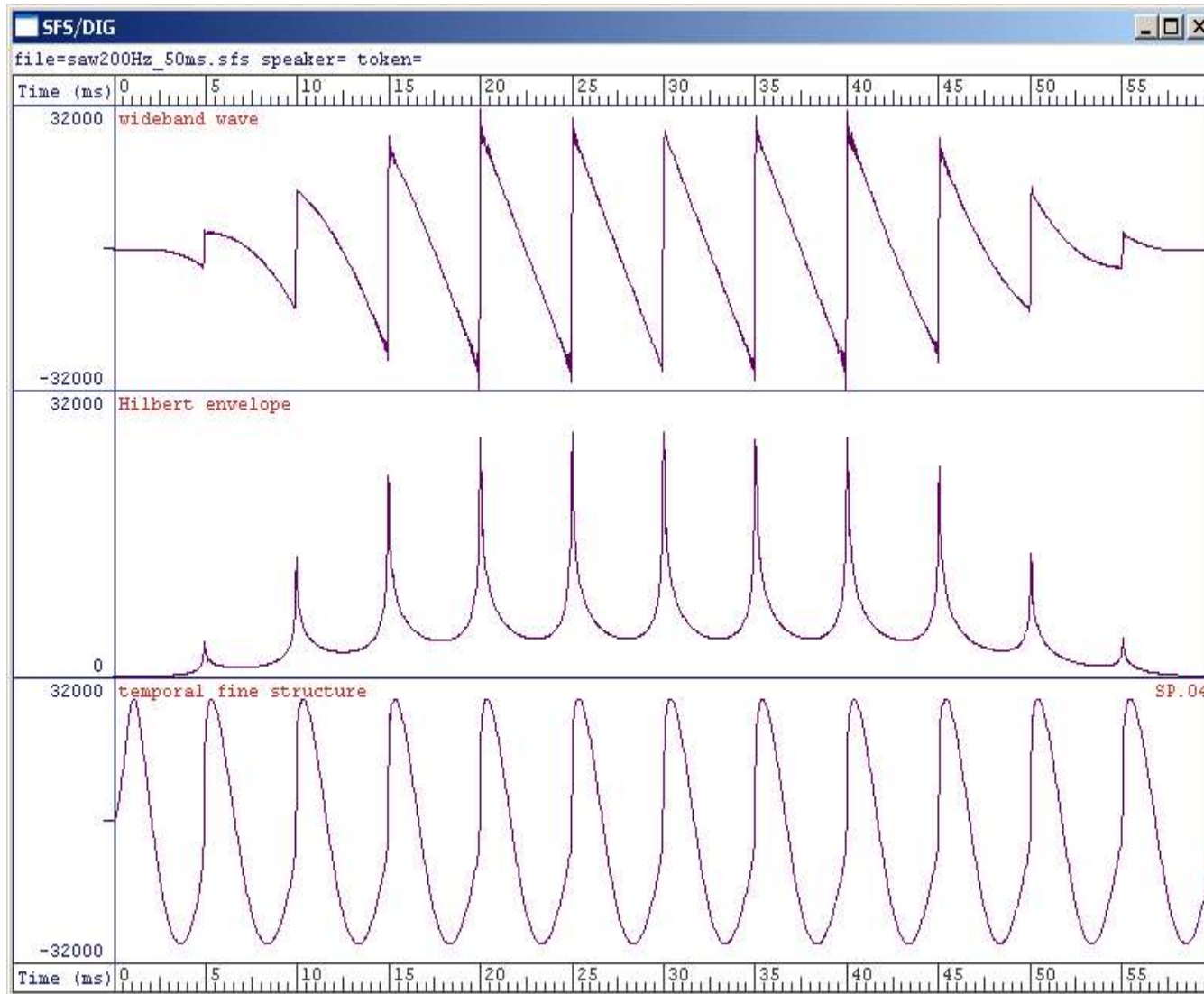

original wave

=

envelope

x

TFS

Decomposing a 'clown'

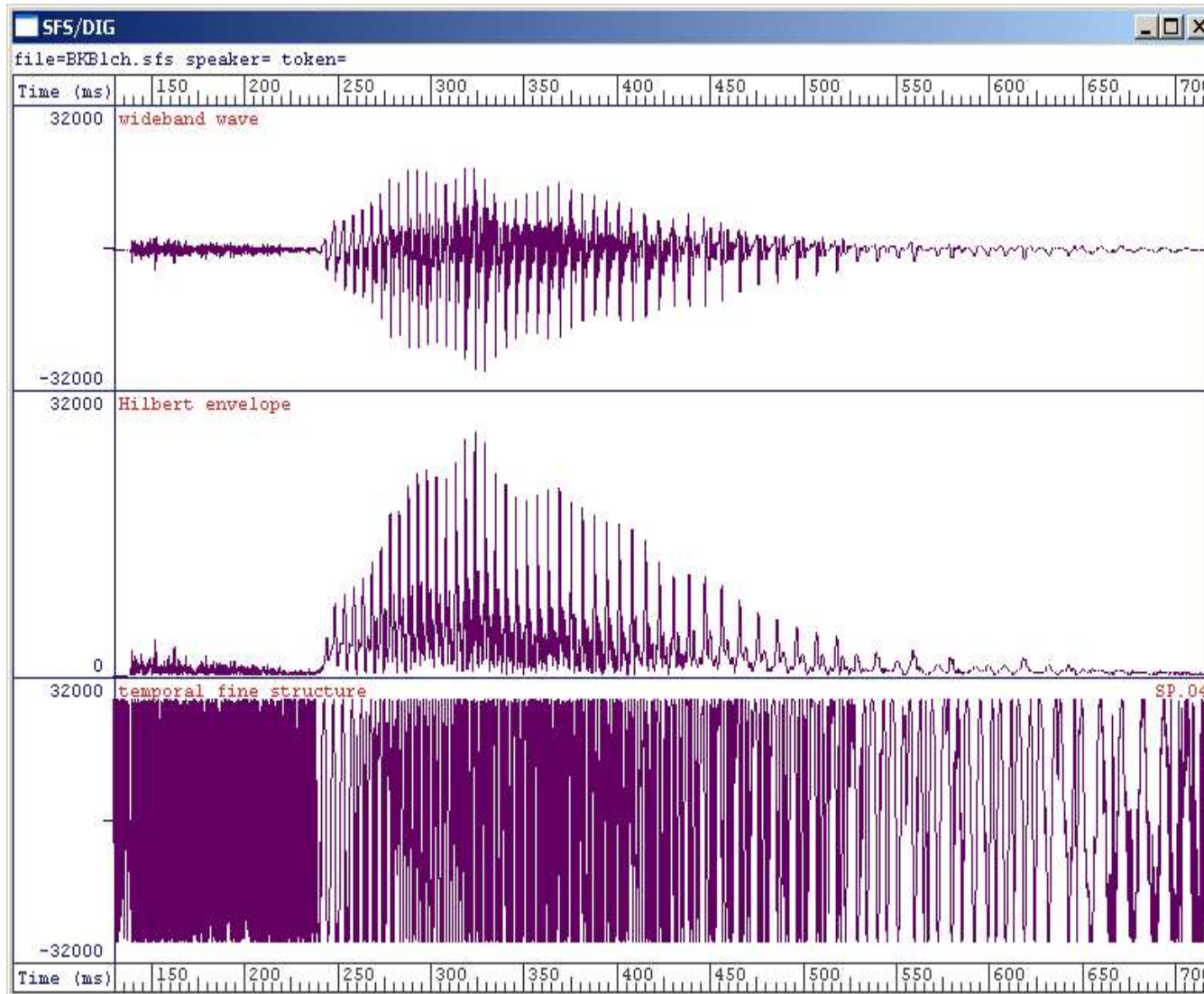

original wave

=

envelope

x

TFS

Look up close

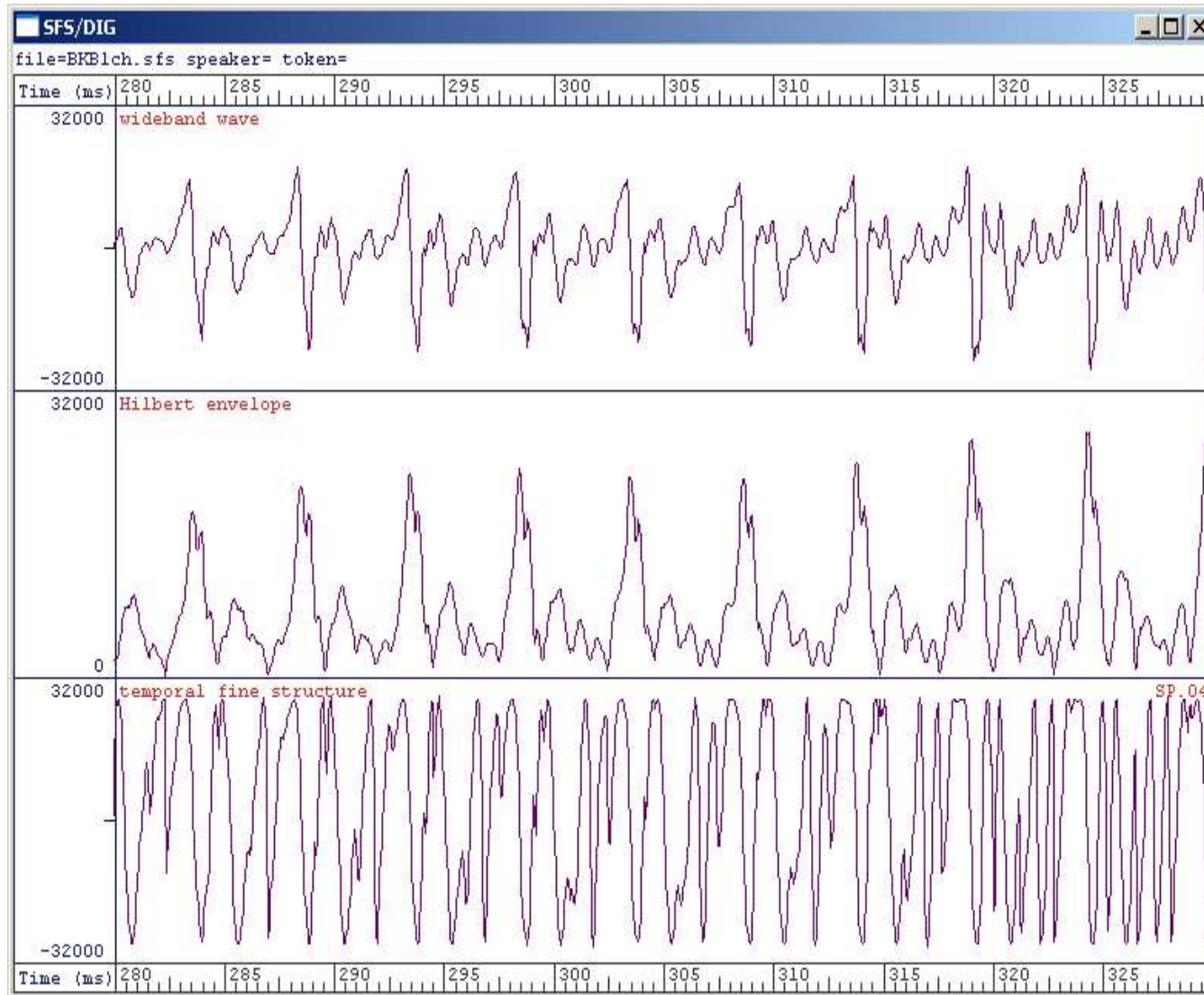

original wave

=

envelope

x

TFS

(hardly a 'sinusoid'!)

A complication

- The auditory periphery acts as a kind of a filter bank
- So auditory nerve fibres transmit information about a bandpass filtered version of the original wide-band wave
- It only makes sense to apply the decomposition to a bandpass filtered version of the original wave
- Filter bandwidth will depend on
 - whether a listener is hearing-impaired
 - frequency in normal and hearing-impaired listeners
 - whether a listener is using a cochlear implant

Sawtooth: auditory filtering @ 200 Hz

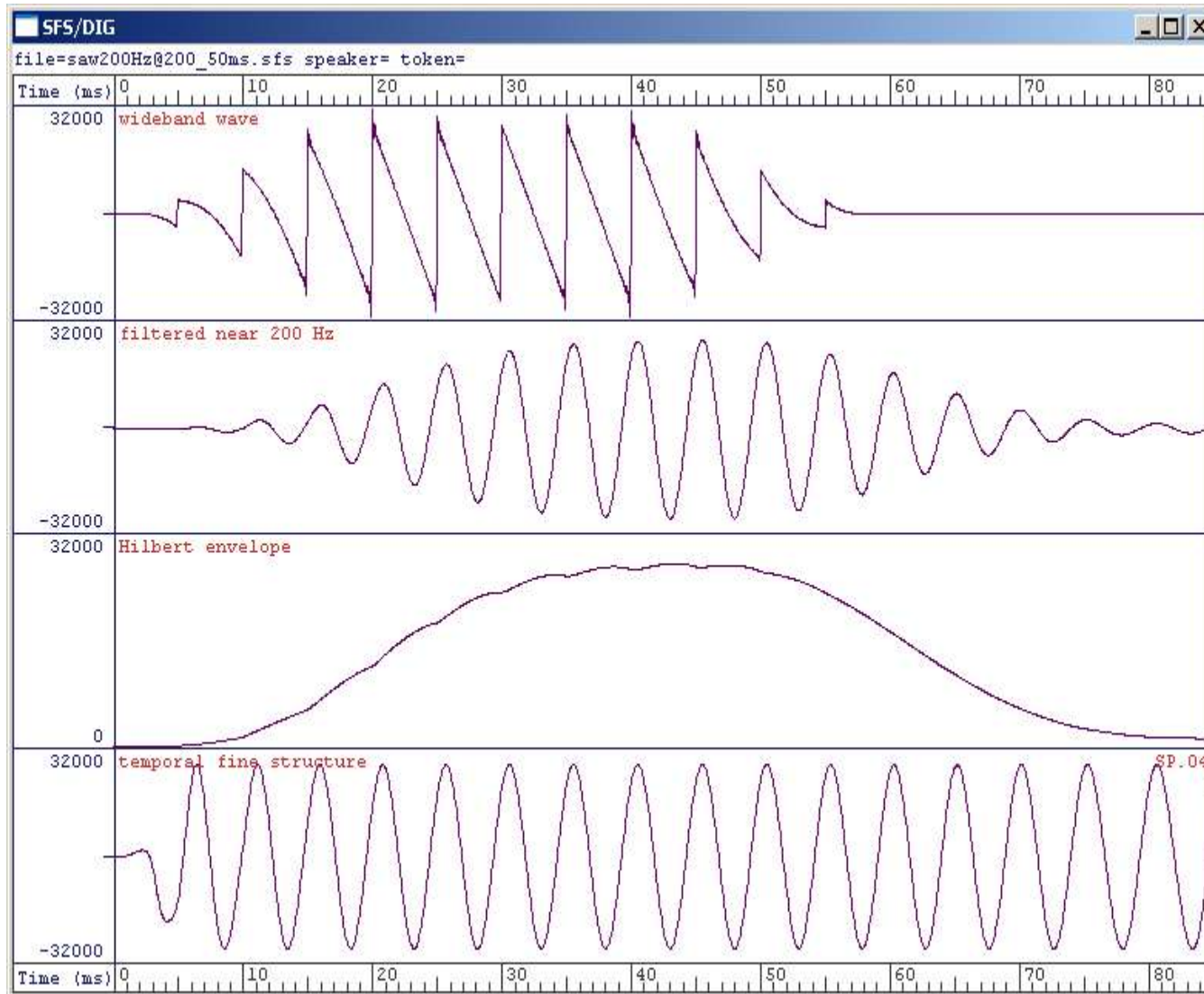

original wave

filtered wave

=

envelope

x

TFS

resolved harmonics — no evidence of periodicity in envelope; strong in TFS

Sawtooth: auditory filtering @ 2 kHz

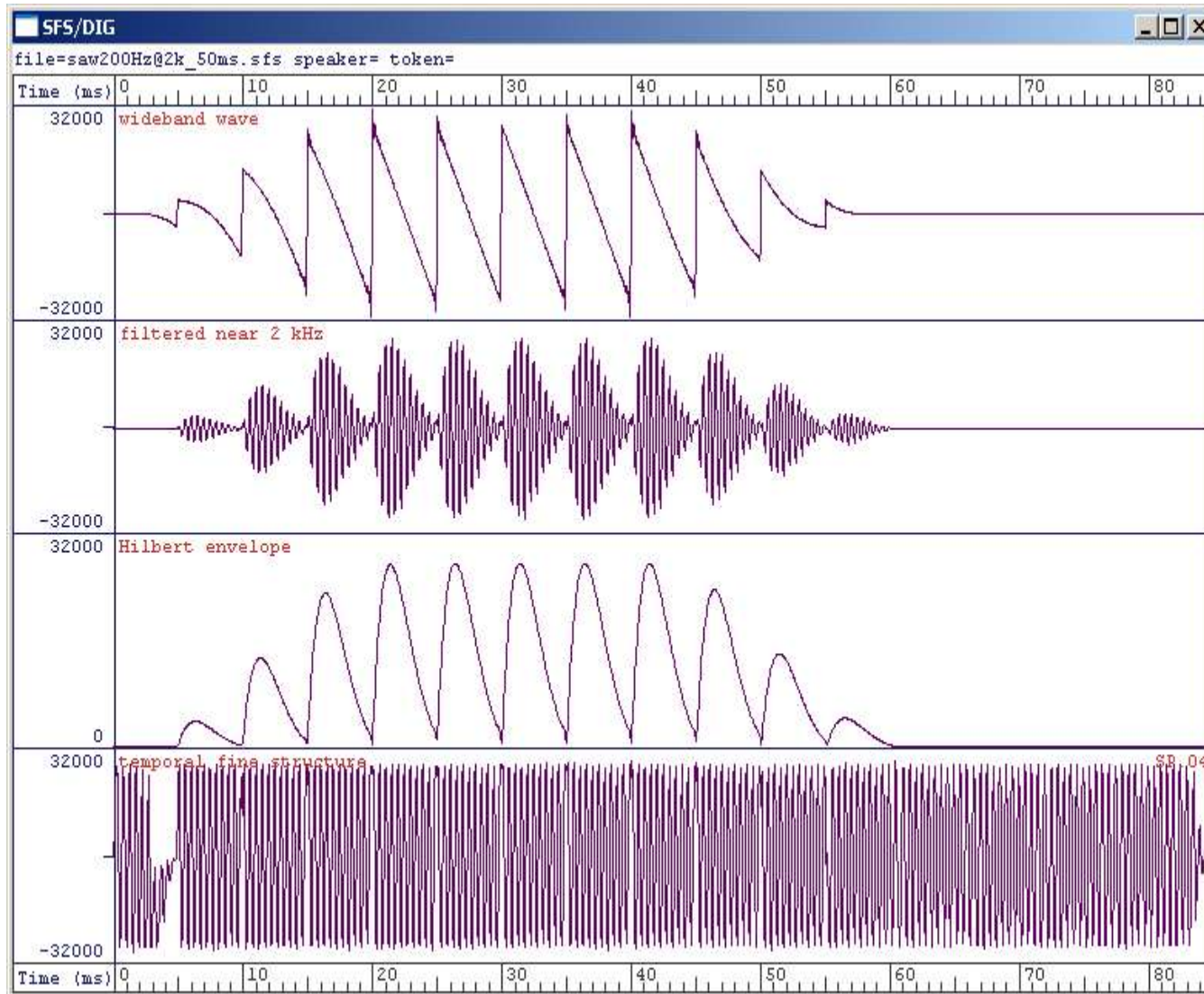

original wave

filtered wave

=

envelope

x

TFS

unresolved harmonics — periodicity evident in envelope; weak in TFS

A 3-way partition of temporal information

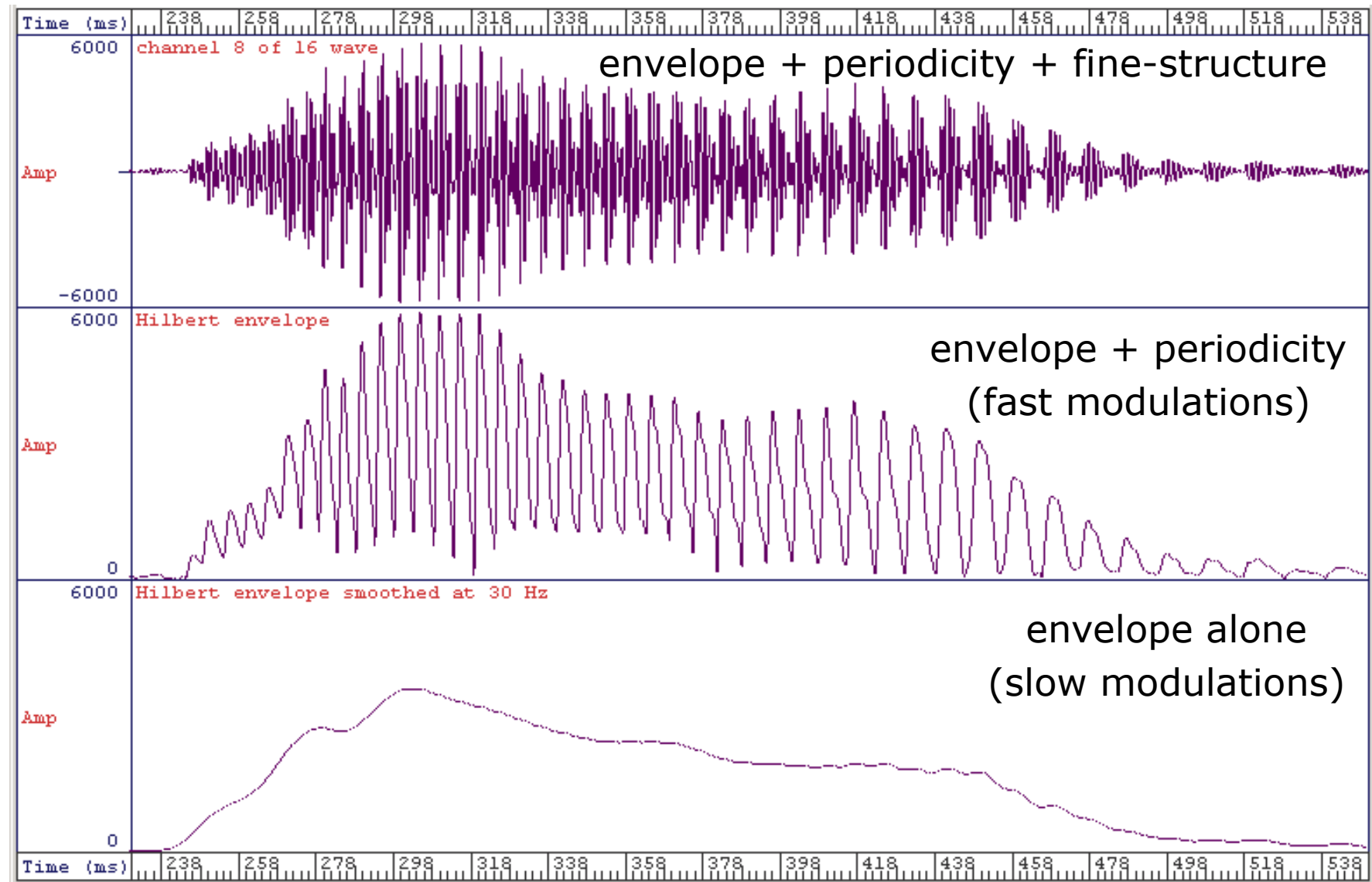

All 3 temporal features preserved in the auditory nerve (slower modulations not shown)

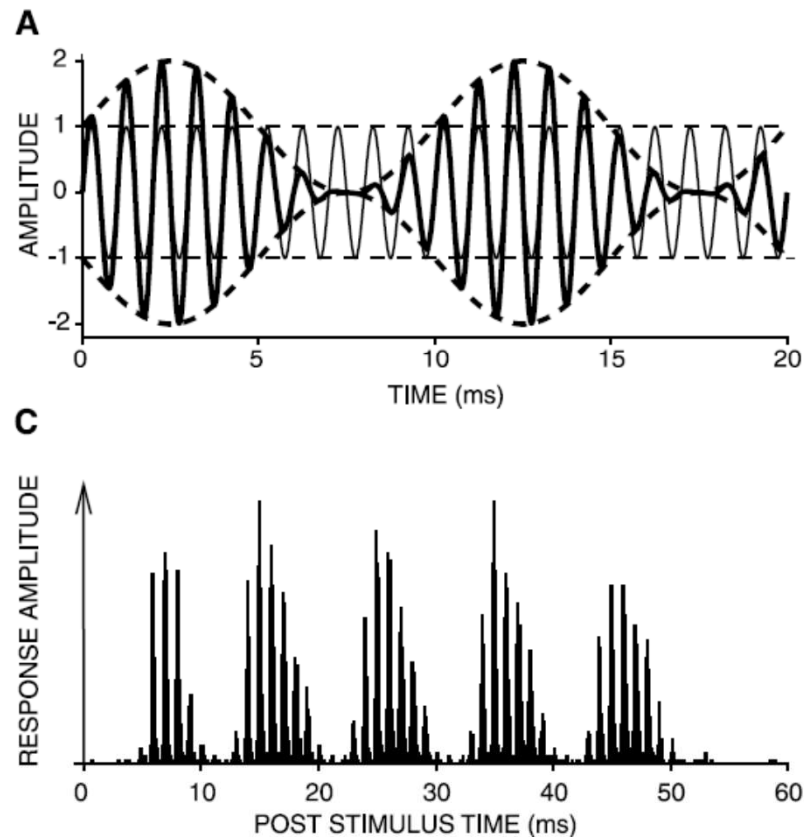

FIG. 1. *A*: superimposed waveforms of an unmodulated 1,000-Hz tone (thin line) and the same tone sinusoidally amplitude modulated (AM) (thick line) at 100% with a modulation frequency of 100 Hz, according to Equation 1. Dashed lines indicate the envelope. The amplitude is referenced to the peak amplitude of the unmodulated tone. *B*: idealized spectrum of the AM tone in *A*. At 100% modulation, the amplitude of the sidebands is half that of the carrier, i.e., a difference of 6 dB. *C*: average response in the form of a poststimulus time (PST) histogram of a nerve fiber to the signal shown in *A* (stimulus duration, 50 ms). *D*: spectrum of the PST histogram in *C*. The components at carrier frequency (f_c) and $f_c \pm$ modulation frequency (f_m) indicate that there is phase-locking to the fine-structure of the stimulus waveform. The component at f_m is prominently present in the response but is absent in the stimulus (*B*). The small circle on the ordinate indicates the average firing rate.

Joris *et al.*
2004

Everyone agrees that ...

- 'Slowish' envelopes (<30 Hz or so) are really important for speech perception
- Distinguish two features
 - Envelope variations that are highly correlated across frequency
 - And those that are not.

Correlated and uncorrelated (across frequency) envelope modulations

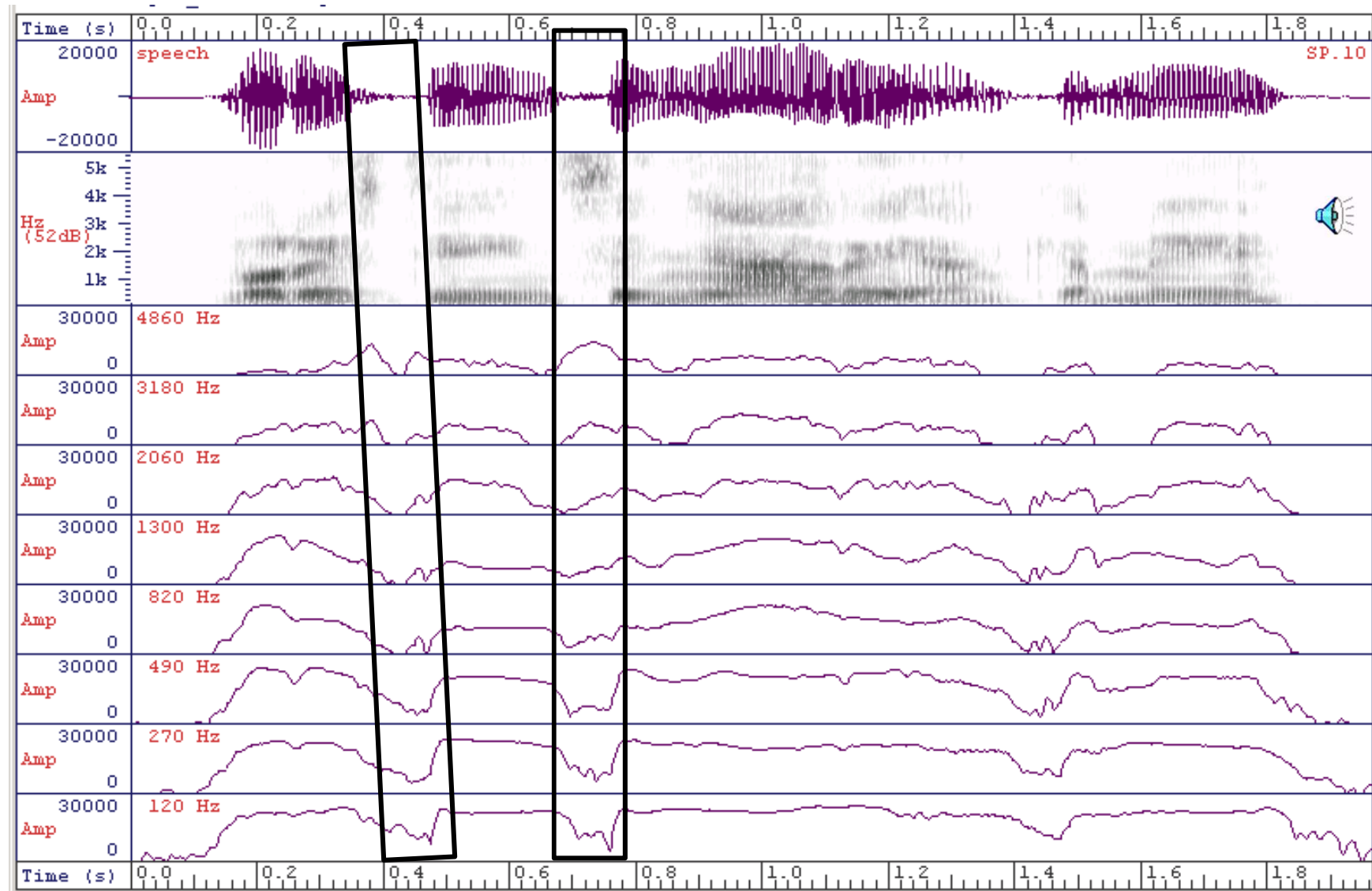

Correlated envelopes in speech – one source of cues to consonants

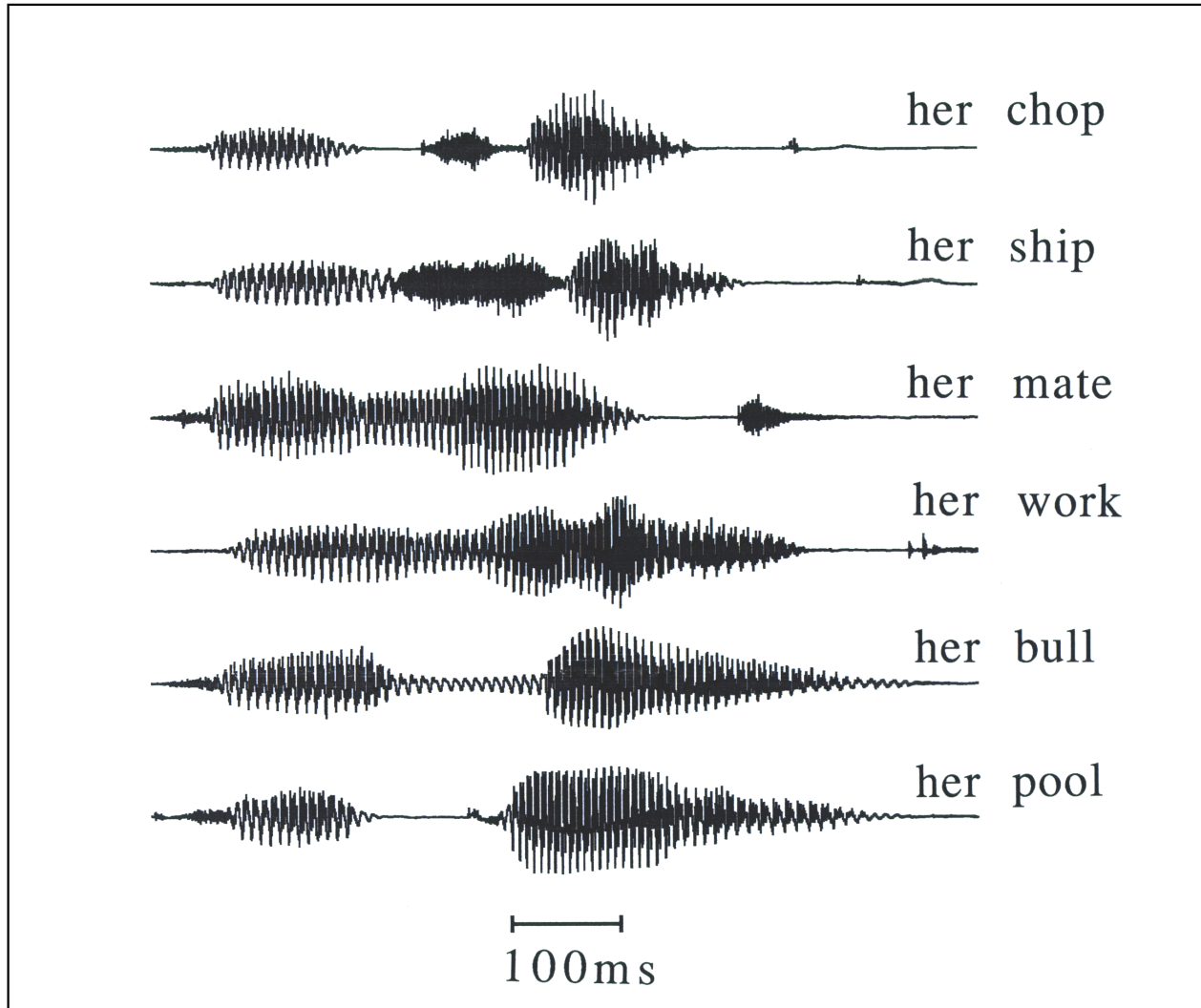

Changing manner of articulation *push ship vs. push chip*

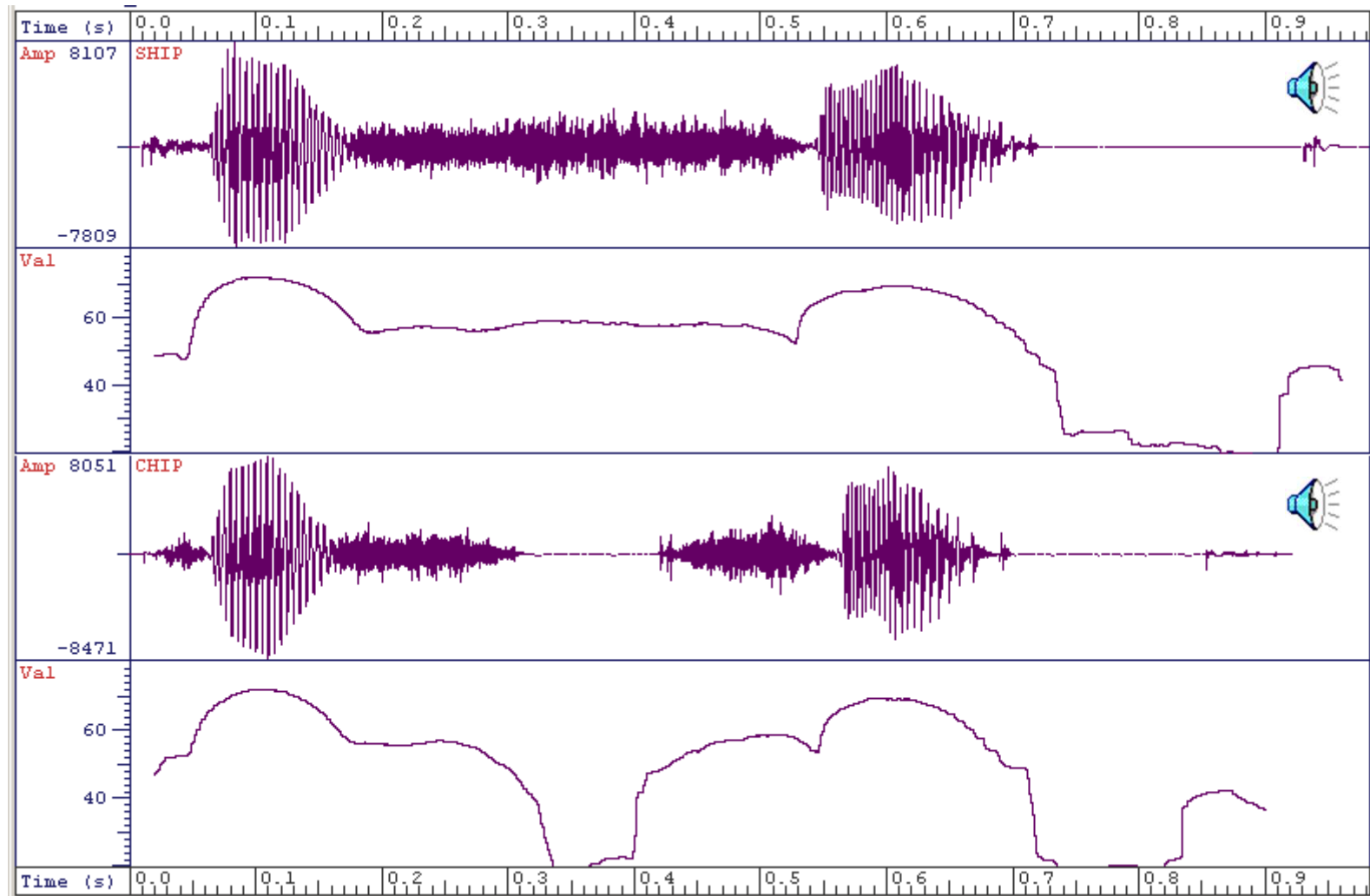

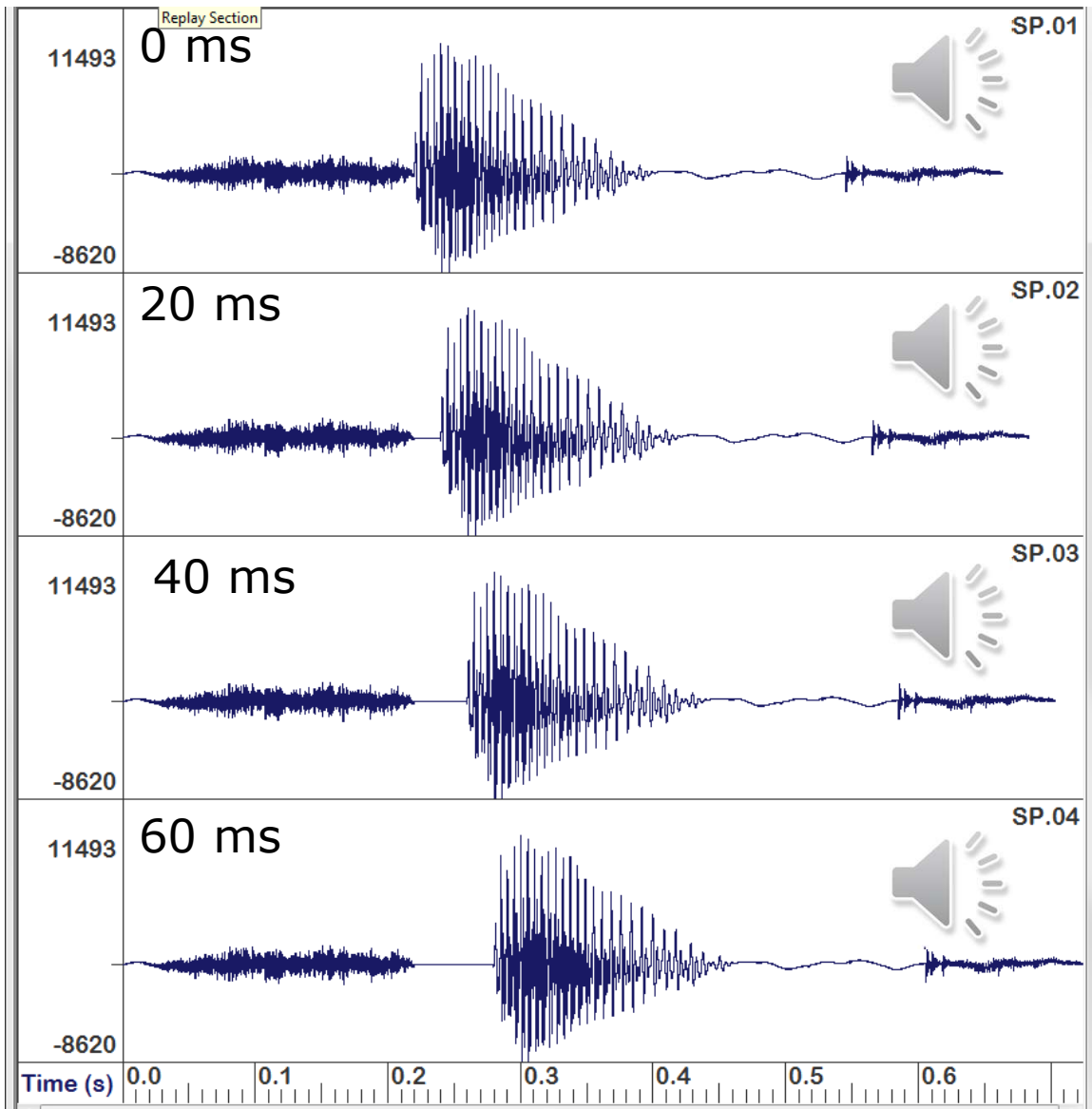

Spectral dynamics are encoded in uncorrelated across-channel envelope modulations

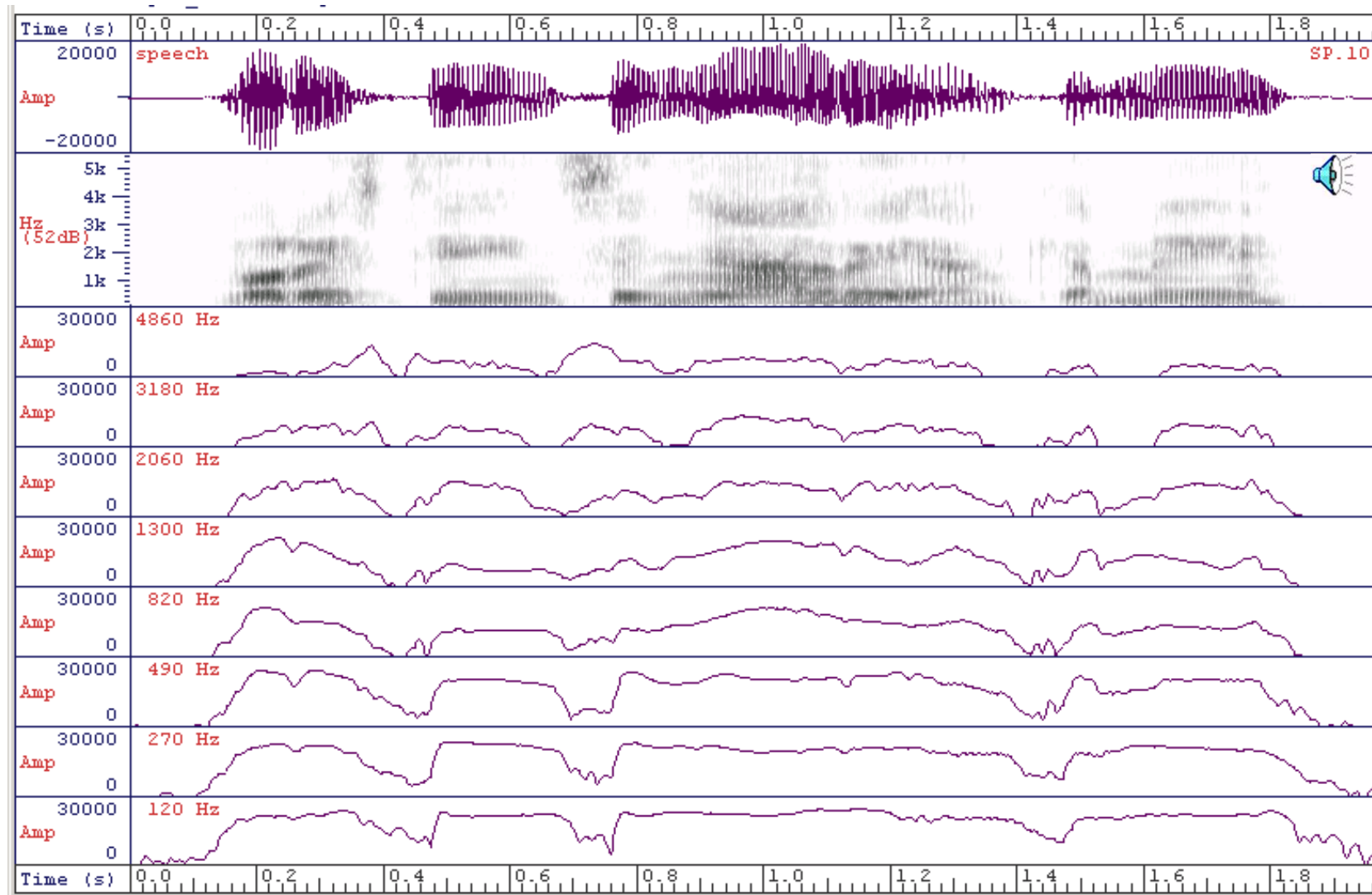

Proof that envelopes are sufficient: Noise-excited vocoding

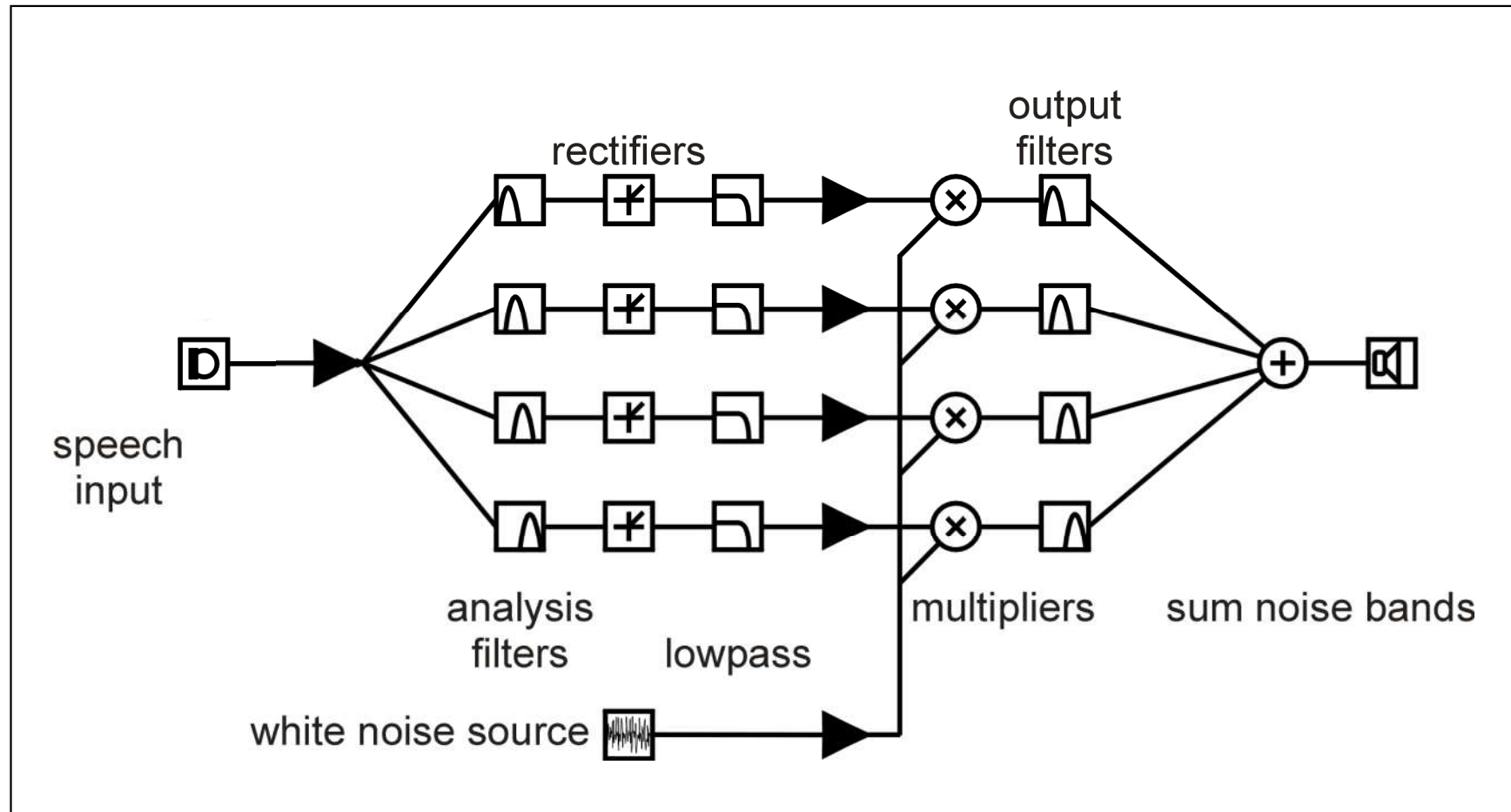

more or less preserves envelopes, destroys TFS

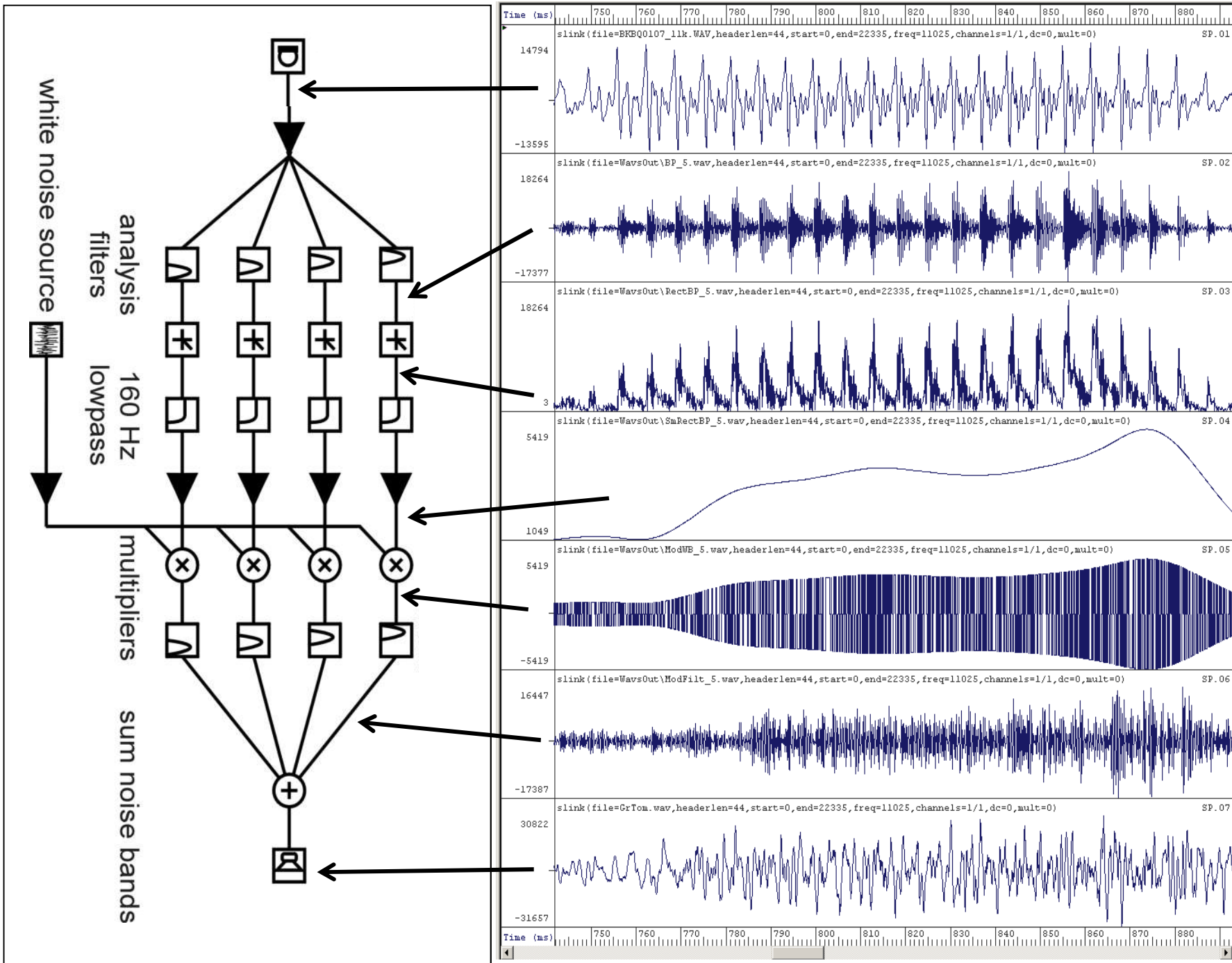

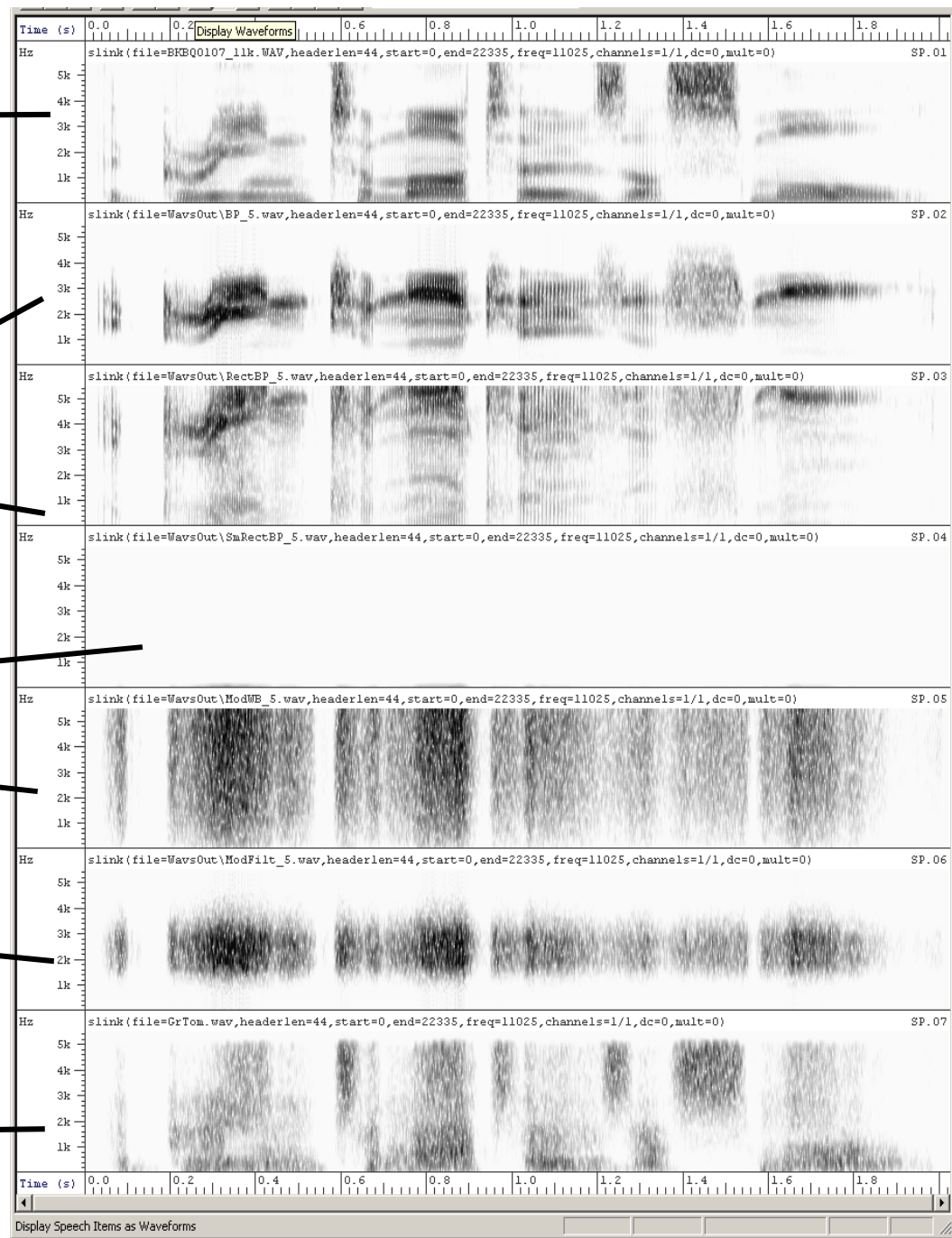
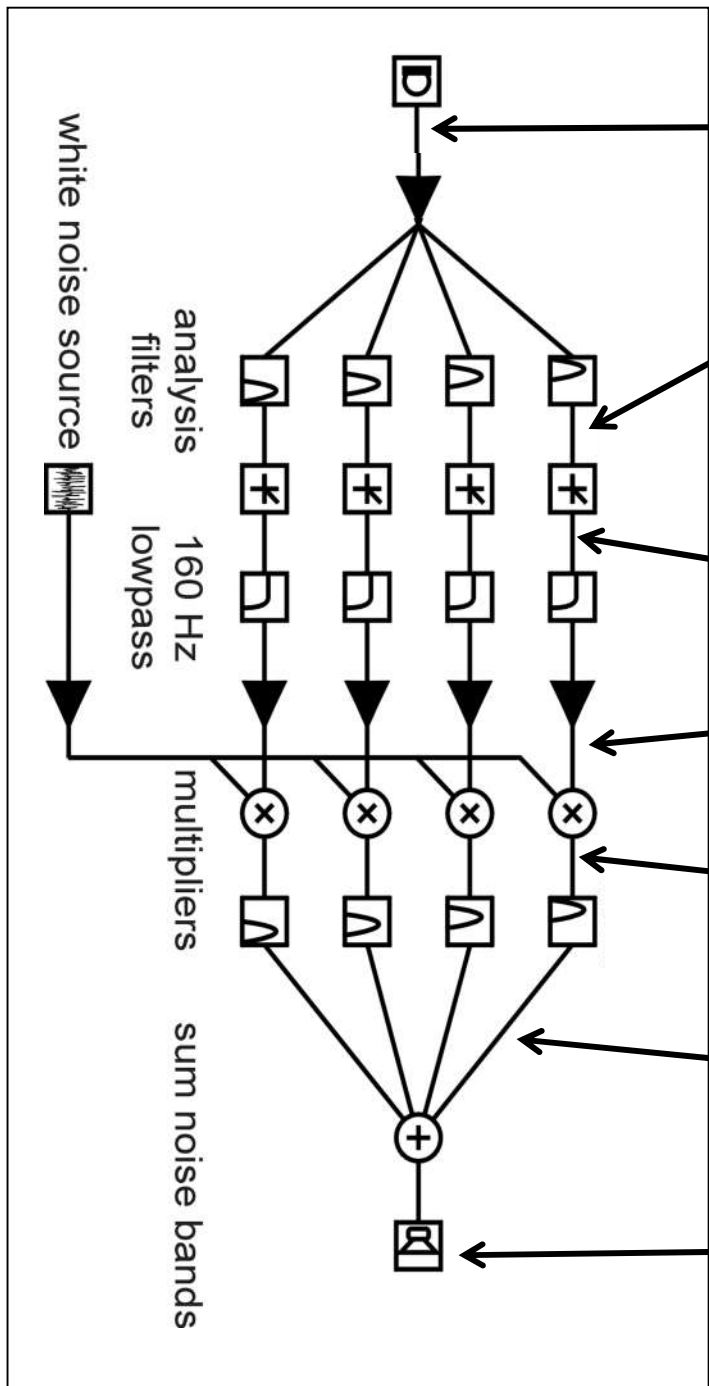

Note similarity to normal cochlear processing

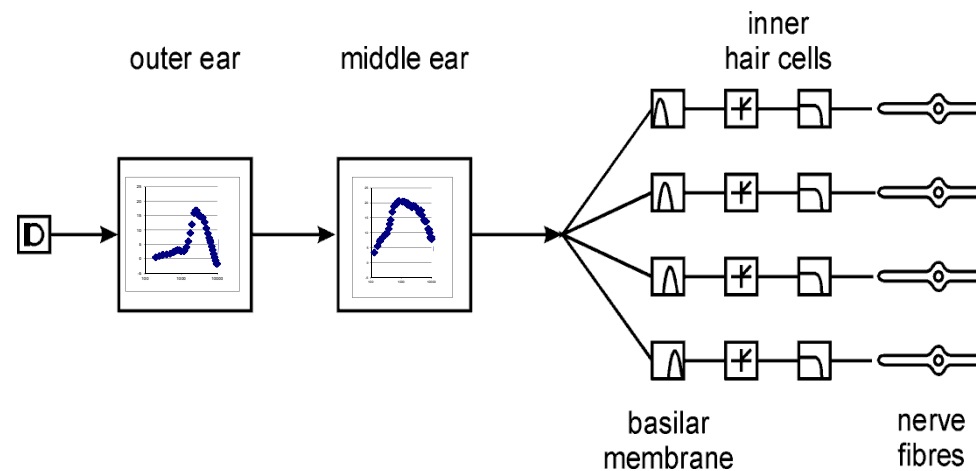
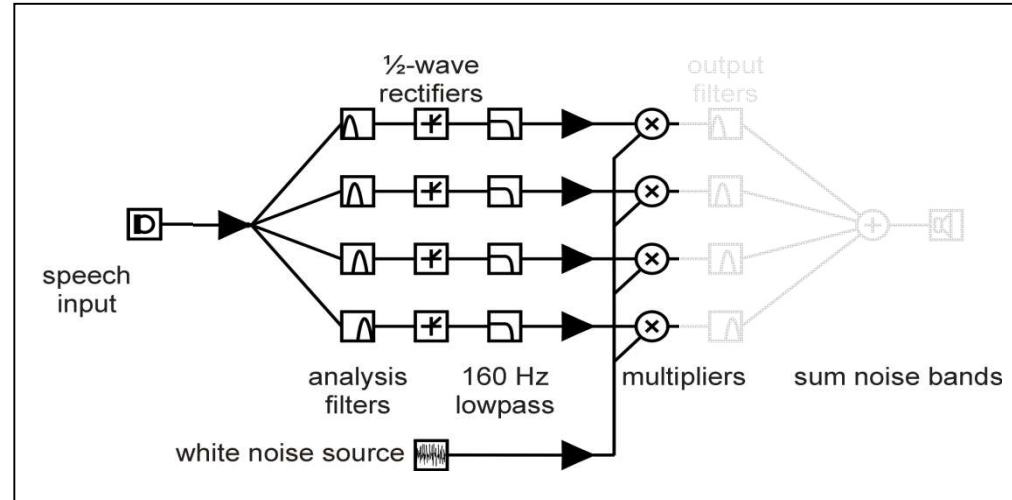

Separate channels in a 6-channel simulation

file=1to6.sfs speaker= token=

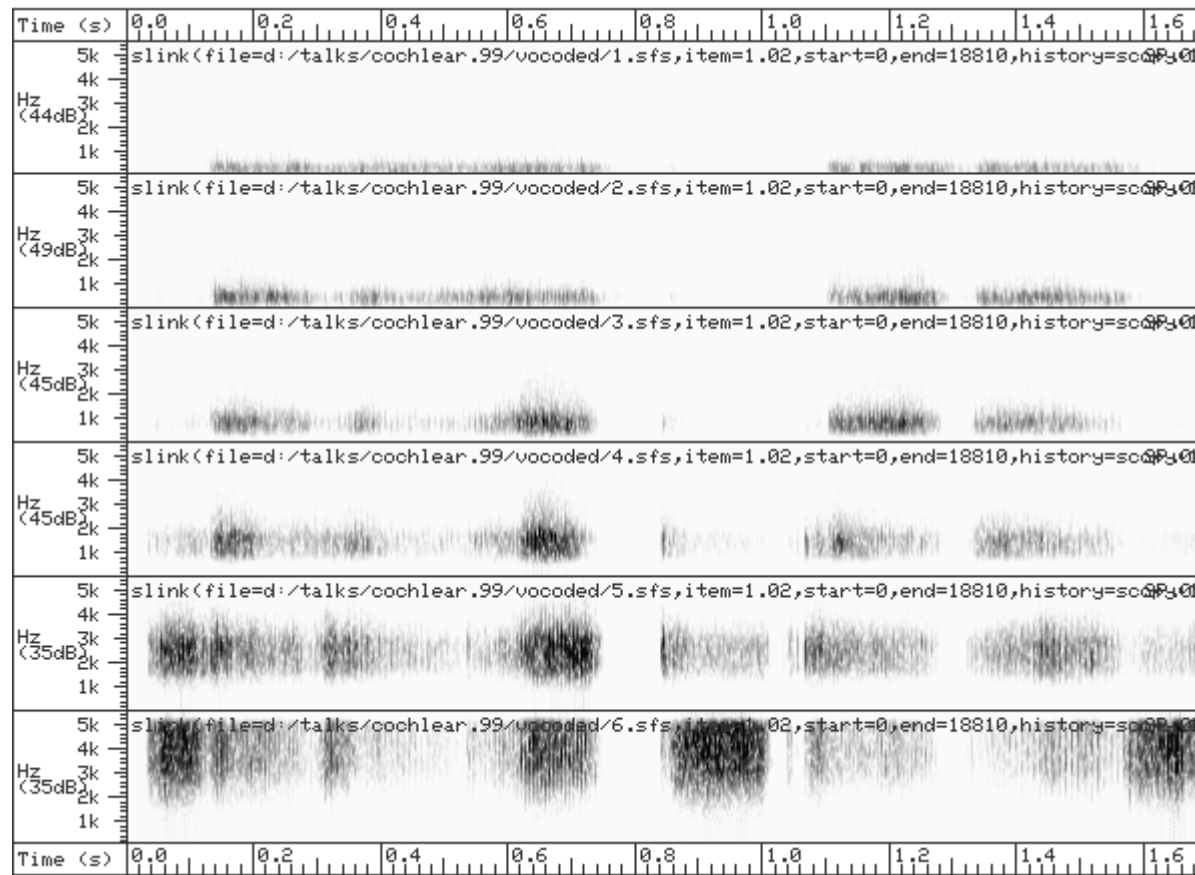

... and when summed together.

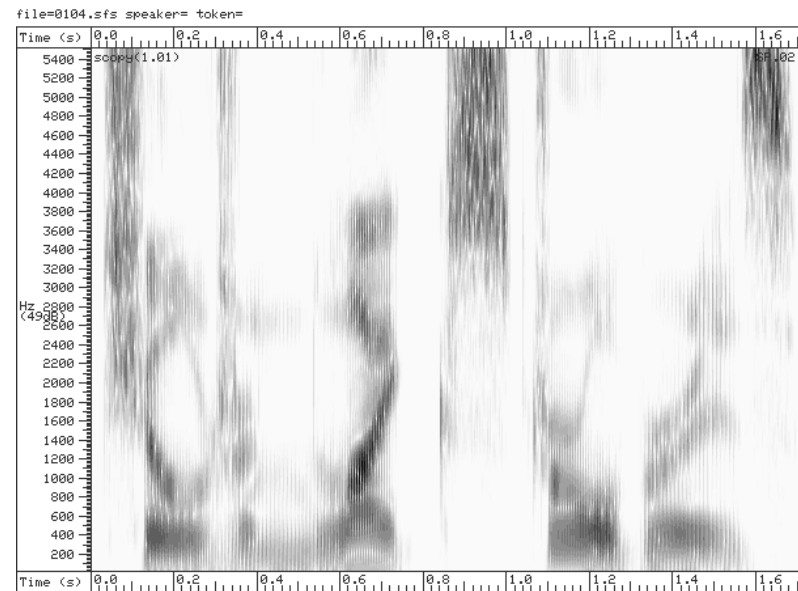
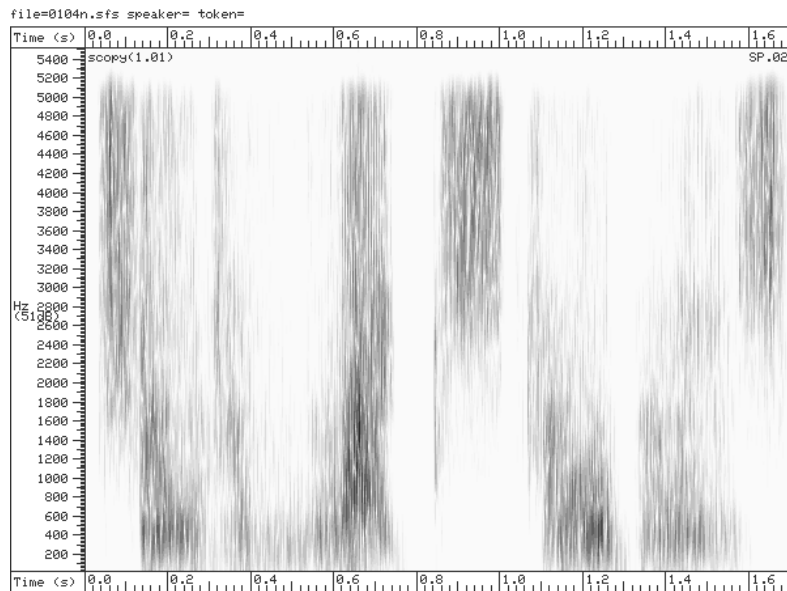

Never mind the quality... feel the intelligibility.

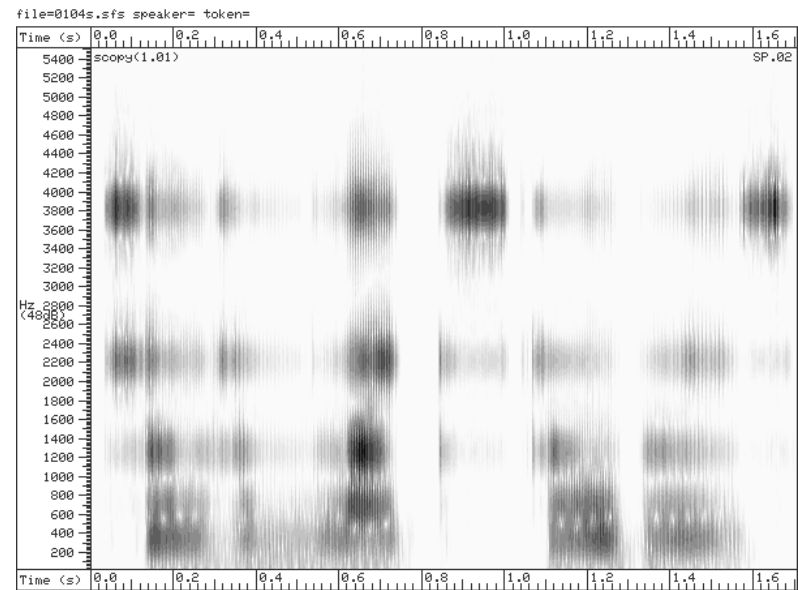
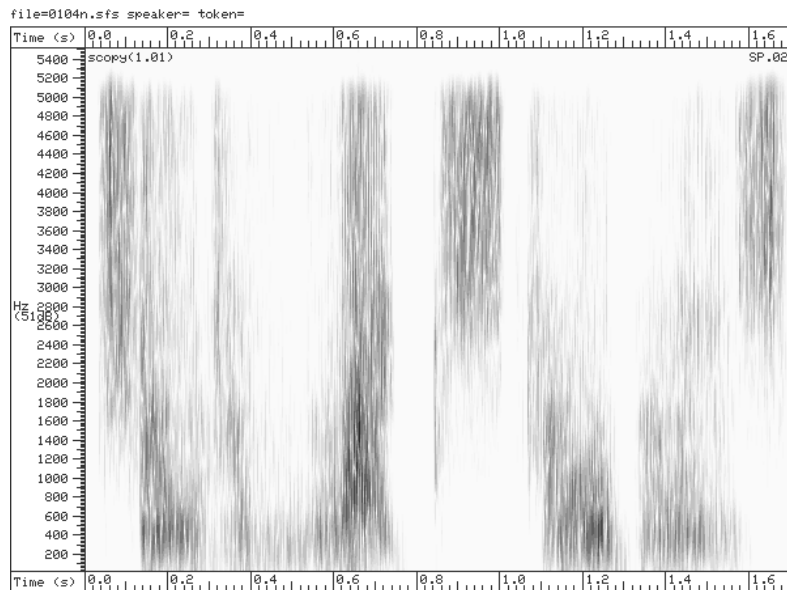

Effects of envelope smoothing on speech - modulations below 10 Hz are most important

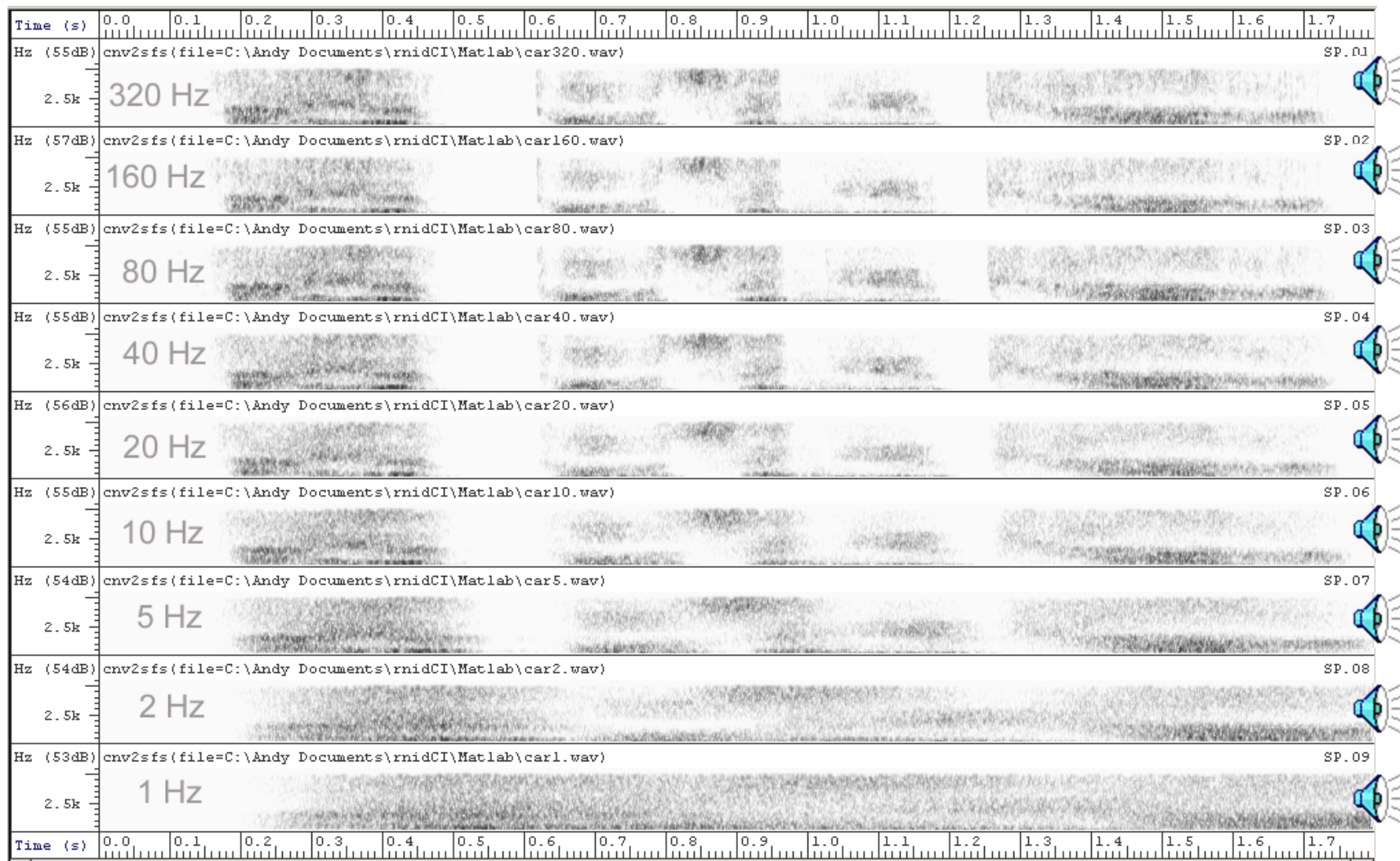

Modulation depth matters, too

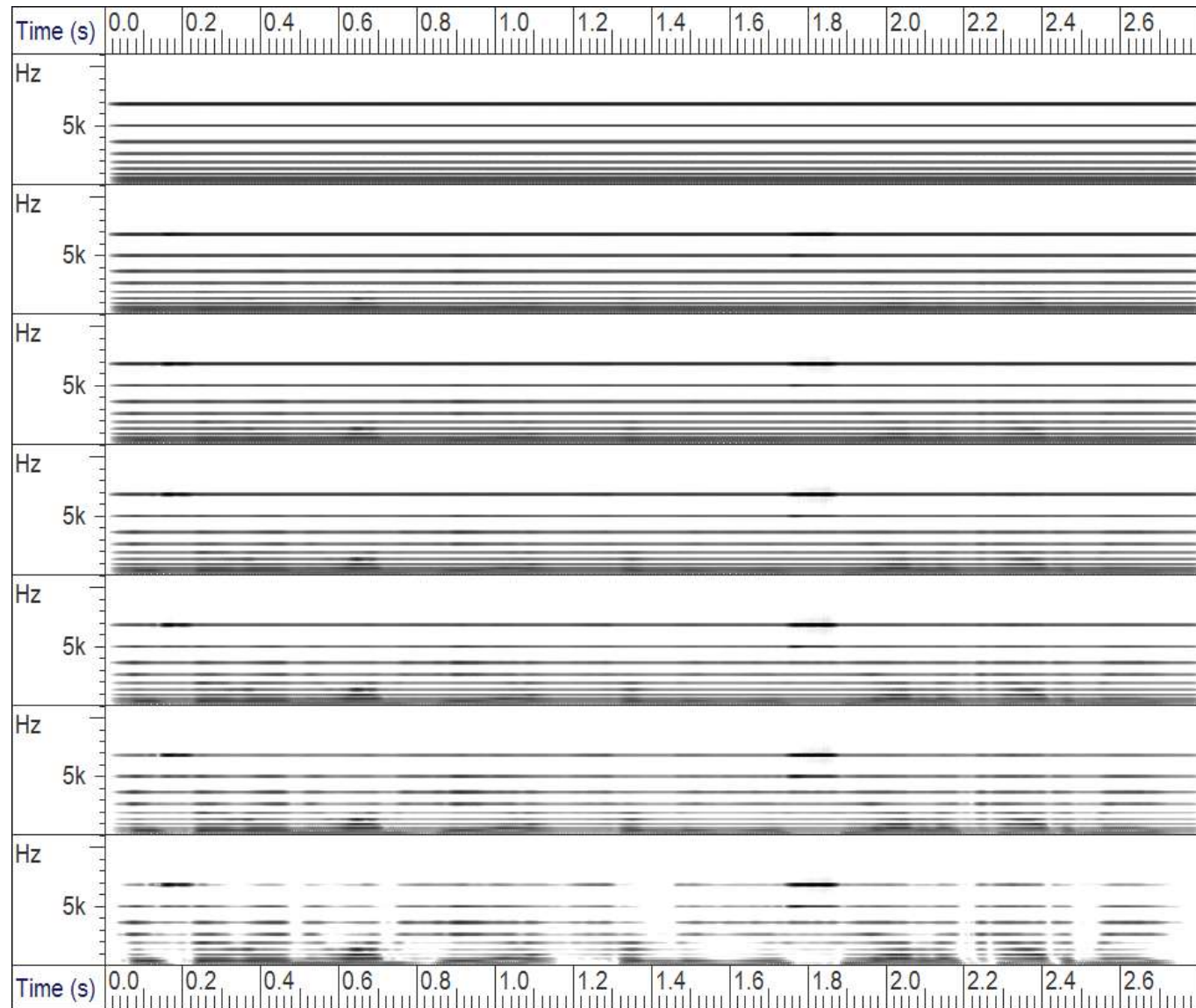

So what's missing in envelope?

- TFS *is* important for ...
 - Localisation
 - Perception of melodic pitch
 - Intonation and tone, for the TFS of a periodic sound
- In CI research, TFS often used as a code word for 'pitch perception'
 - Even though poor pitch perception may also arise from impaired frequency selectivity.

NHLs do use TFS for pitch

Types of Spectrogram

Wide-band

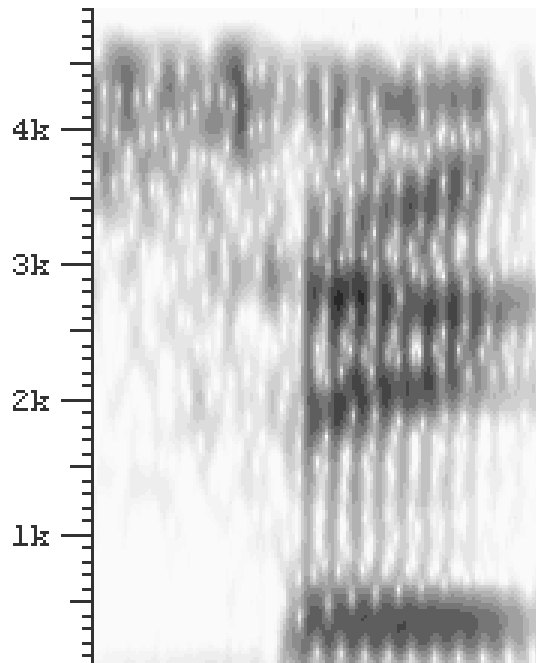

Narrow-band

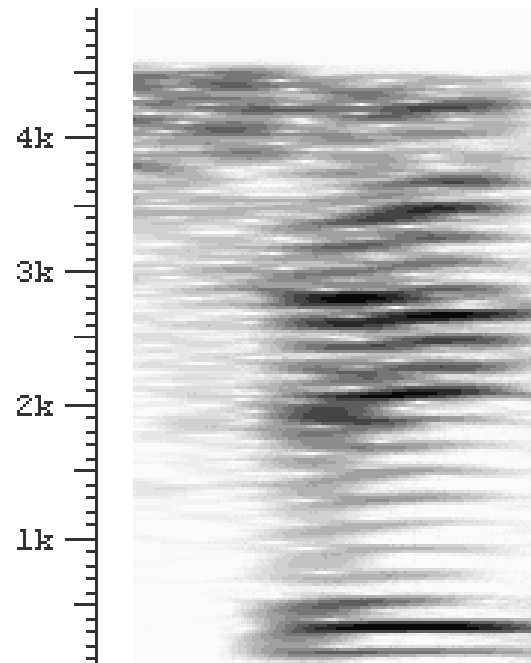

Auditory

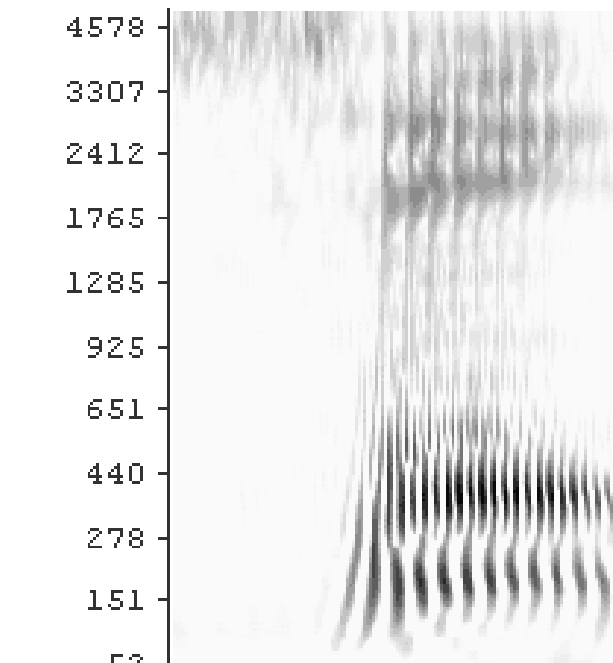

An auditory spectrogram looks like a wide-band spectrogram at high frequencies and a narrow-band spectrogram at low frequencies (but with more temporal structure).

Summary

- Waveforms (after any filter bank/spectral analysis) can be decomposed into the product of
 - An envelope (something fairly slow)
 - often divisible into slower and faster components
 - A TFS (something fast)
- Envelope is necessary and sufficient for speech perception in quiet
- One serious limitation of CIs (and HI listeners) especially for speech in noise may be poor access to TFS information
 - But the representation of TFS also depends upon frequency selectivity, so it is not necessarily easy to separate out their effects